

Linear Actuators for Precision Motion Control

Solutions featuring Novel Piezoelectric Motors and Classical Motors



Precision Linear Actuators Overview

Motion Control with Piezoelectric / Servo / Stepper Motors

PI is the leading manufacturer of ultra-high-precision actuators for nanopositioning and micropositioning applications in industries such as Semiconductors; Biotechnology and Medicine; Lasers, Optics, Microscopy; Aerospace Engineering; Precision Machining; Astronomy and Microsystems Technology.



Section A

NEXACT® Compact Piezo Stepping Motor Actuators

- PiezoWalk® Drive
- Compact Dimensions
- Forces to 10 N
- <0.1 nm Resolution
- Self-Locking at Rest
- Travel to 25 mm (Basically Unlimited)
- Velocity to 10 mm/s
- Non-Magnetic, Vacuum Compatible

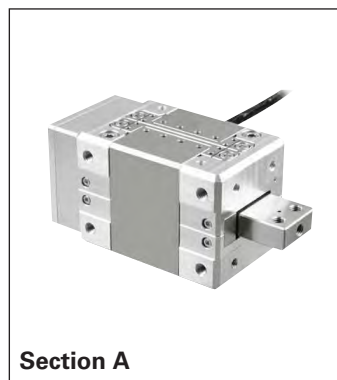

Section A

NEXLINE® High-Force Piezo Stepping Motor Actuators

- PiezoWalk® Drive
- Non-Magnetic, Vacuum Compatible
- Forces to 600 N
- <0.1 nm Resolution
- Self-Locking at Rest
- Basically Unlimited Travel
- High Reliability, Long Life
- High-Dynamics Mode Compatible

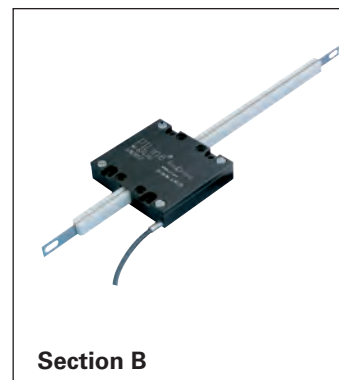

Section B

PILine® Ceramic Ultrasonic Piezo Motor Actuators

- High-Speed Piezomotors and Drives
- Velocity to 800 mm/s
- Compact Dimensions
- Travel to 150 mm (Basically Unlimited)
- Forces to 7 N
- Self-Locking at Rest
- Resolution to 20 nm
- Non-Magnetic, Vacuum Compatible

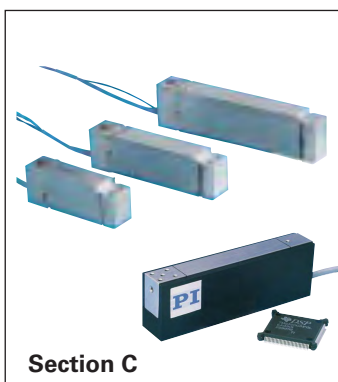

Section C

Flexure-Guided Piezo Actuators

- PICMA® Piezoceramic Multilayer Actuators
- Sub-Nanometer Resolution
- Fast Response (Millisecond-Range)
- Excellent Guiding Precision
- Travel to 1.8 mm



Section D

Piezo Stack Actuators

- PICMA® Multilayer and PICA™ Stack Actuators
- Forces to 100 kN
- Sub-Nanometer Resolution
- Fast Response (to Microsecond-Range)
- High Reliability and Long Lifetime
- Travel to 200 µm

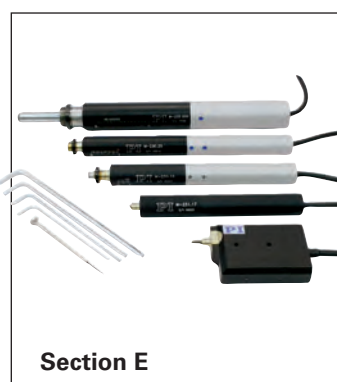

Section E

Motorized Screw Type Actuators

- DC & Stepper Motors
- Forces to 400 N
- Travel to 50 mm
- Resolution to 50 nm



Section F

Motion Controllers (Examples)

- Controllers for Servo Motors and Stepper Motors
- Controllers for Ultrasonic Linear Motors
- Controllers for NEXACT® Linear Motors
- Controllers for Piezo Actuators and Flexure Stages

Visit www.pi.ws for our full selection of motion controllers & software solutions.

Micropositioning, Nanopositioning, NanoAutomation

Cutting-Edge Solutions for Industry and Research



PI headquarters

Positioning Technology - 30 Years Ahead of its Time

PI has been a world market leader in nanopositioning technology and ultra-high-precision motion-control systems for many years. The first nanopositioning systems served research centers working in interferometry and laser technology. Today, entire branches of industry – such as the semiconductor industry, biotechnology and, increasingly, the machine-tool industry – are dependent on progress in nanopositioning.

Key Technologies Under One Roof: A Plus for Our Customers

PI has a strategy of vertical integration with all key technologies developed and maintained in one company. This permits direct control over every step from conception to shipment, optimizing quality and cost. As a customer, you, too, can profit from our over 30 years experience in micro- and nanopositioning.

PI can react quickly to development and production needs of OEM customers – even for highly complex custom products and assemblies.

Applications

Today PI delivers Micro- & NanoPositioning solutions for all important high-tech markets:

- Semiconductors
- Data Storage
- Photonics, Fiber Optics, Telecom
- Life Sciences
- Lasers, Optics, Microscopy
- Aerospace Engineering
- Precision Machining
- Astronomy

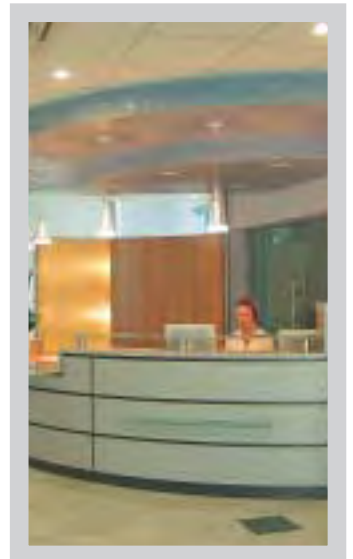

PI-USA headquarters in Massachusetts

Piezo Stepping Motor Basics

PiezoWalk® Precision Drives – Millimeter Travel, Nanometer Resolution, High Forces

PiezoWalk® drives break away from the limitations of conventional Nanopositioning actuators. They offer a basically

unlimited travel range and still provide the characteristic features of a piezoelectric actuator: an open-loop resolution down to 30 picometers and a very high stiffness for dynamic operation and force generation. PI offers two product lines

based on different versions of the PiezoWalk® principle: NEXLINE® and NEXACT®. Both provide specific advantages depending on the application.

PiezoWalk® piezo stepping drives usually consist of several individual piezo actuators and generate motion through succession of coordinated clamp / unclamp and shear-motion cycles (steps). Each cycle provides only a few microns of movement, but running at hundreds of hertz, the drive achieves continuous motion in the mm/second range.

ity. These properties are typically better for piezo stepping actuators compared to inertia drives or ultrasonic motors. The operation is possible in two different modes: a high-resolution, high dynamics analog mode within a single step, and a step mode with virtually unlimited travel range.

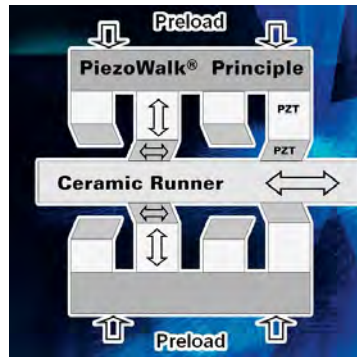
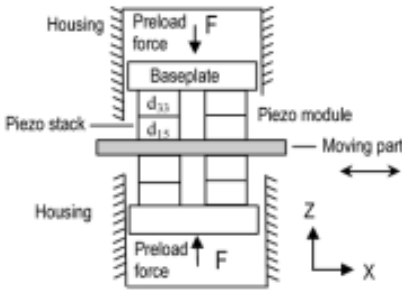

NEXLINE® linear actuator principle



Custom PiezoWalk® linear actuator

The PiezoWalk® working principle provides high force capabilities, resolution and repeatabil-

Features and Advantages of PiezoWalk® Drives

- Very high resolution, limited typically only by the sensor. In fine-adjustment, analog mode, resolution of 30 picometers has been demonstrated.
- High force generation and stiffness. NEXLINE® drives can hold and generate forces to 600 N, NEXACT® to 15 N.
- PiezoWalk® drives hold a stable position to nanometer level in power-off mode. Due to the actuator design, the maximum clamping force is applied at rest.
- Because a position can be held with zero operating voltage, leakage currents cannot affect the integrity of the piezo drive.

- PiezoWalk® drives are available for non-magnetic applications such as super-conductivity experiments. They do not create magnetic fields nor are they influenced by them.
- The active parts in PiezoWalk® drives are made of vacuum-compatible ceramics. The drives also work in UV-light environments.
- NEXLINE® drives can survive shock loads of several g during transportation.
- PiezoWalk® drives are available in three levels of integration to provide flexibility for OEMs: OEM drives, packaged actuators and integrated into complex positioning systems such as multi-axis translation stages or 6-DOF Hexapods.



50 picometer steps with a NEXLINE® drive, measured with external ultra-high-resolution capacitive sensor. This performance provides a big safety margin for next generation nanotechnology applications



6-axis parallel-kinematic nanopositioning system (Hexapod) with N-215 based NEXLINE® high-load actuators for use in strong magnetic fields

Piezo Stepping Motor Basics

NEXLINE® High-Force Drives for Nanopositioning

NEXLINE® systems are based on very rugged, high-efficiency shear and clamping actuators and incorporate a preloading mechanism to provide pushing and holding forces up to 600 N with high lifetime. The rigid design with resonant frequencies of hundreds of hertz allows the construction of very stiff structures and helps to suppress vibration. The analog operating mode can be used for dithering and active vibration cancellation.

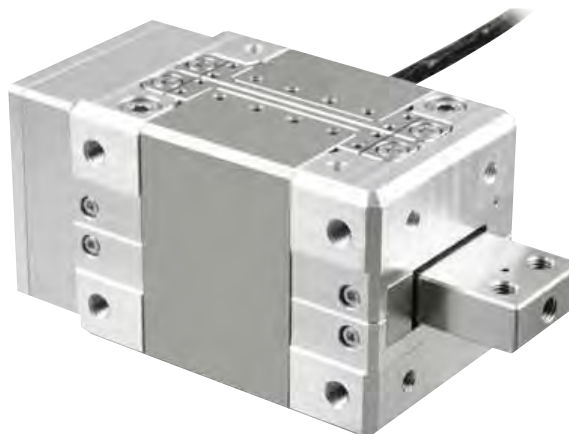

N-215 high-load NEXLINE® linear drive provides holding forces to 600 N and 20 mm travel

Compact NEXACT® Drives for Moderate Forces

NEXACT® drives use bending actuators which combine the feed forward and the clamping cycles. They provide push/pull forces to 15 N with maximum velocities of more than 10 mm/s at low operating voltages of 40 V. The compact and cost-effective NEXACT® drives are available with various drive electronics, ranging from cost-effective OEM drives for open-loop operation in stepping mode to the sophisticated E-861 servo-controller for high-resolution, closed-loop linear translation stages.



NEXLINE® linear actuator principle

N-310 NEXACT® OEM Miniature Linear Motor/Actuator

Compact, High-Speed PiezoWalk® Drive



- 20 mm Standard Travel Range, Flexible Choice of the Runner Length
- Compact and Cost-Effective Design
- 0.03 nm Resolution**
- To 10 N Push/Pull Force
- Low Operating Voltage
- Self Locking at Rest, No Head Dissipation, Nanometer Stability
- Non-Magnetic and Vacuum-Compatible Working Principle

N-310 NEXACT® PiezoWalk® linear drives feature travel ranges of 20 mm and push/pull force capacities to 10 N in a compact package of only 25 x 25 x 12 mm. With their high resolution, NEXACT® drives, are ideal for high-precision positioning over long travel ranges.

Application Examples

- Semiconductor technology
- Wafer inspection
- Nano lithography
- Surface Measurement Technique
- Profilometry
- Microscopy
- Motion in strong magnetic fields

The N-310 can be operated in open-loop and closed-loop mode (with the addition of an external position sensor). A variety of NEXACT® controllers facilitates the integration into micro or nanopositioning applications.

Advantages of PiezoWalk® Piezo Stepping Drives

- NEXLINE® and NEXACT® drives offer several advantages over traditional drive technologies:
- Resolution in the picometer range
 - Compact dimensions
 - High drive forces from ten newtons (NEXACT®) up to several hundred newtons (NEXLINE®)
 - High-dynamics performance with sub-microsecond response

- Self-locking when powered down; no holding current
- Zero backlash, no wear or maintenance, no mechanical components like gears or leadscrews.
- Non-Magnetic and Vacuum Compatible Operating Principle

Working Principle for Application Flexibility

NEXACT® PiezoWalk® technology overcomes the limitations of conventional nanopositioning drives and combines virtually unlimited travel ranges with high stiffness in a very small package. Furthermore, NEXACT® actuators provide piezo-class resolution (far below one nanometer) and millisecond responsiveness. The special drive design reduces the operating voltage to 45 V and below.

In operation, piezoceramic bending elements act on the runner, which is connected to the moving part of the application. The length of the runner determines the travel range. Force capacity, resolution and velocity are determined by the piezo geometry and drive electronics and are scalable. To move the runner over longer distances the stepping mode is used, whereas for distances smaller than one step, the linear (analog) mode enables high-dynamics positioning with resolutions far below one nanometer.

Wear- and Maintenance-Free

In contrast to ordinary DC or stepper motor drives, the PiezoWalk® drives effect linear motion directly, without the need to transform rotation with mechanical elements such as gears, leadscrews and nuts. Therefore, mechanical

Ordering Information

N-310.11
NEXACT® OEM linear drive, 20 mm, 10 N

N-310.111
NEXACT® OEM linear drive, 20 mm, 10 N, Shifted Cable Exit

Ask about custom designs

limitations such as backlash and wear are eliminated and the drive is maintenance-free.

Self-Locking PiezoWalk® Piezo Stepping Drive

NEXLINE® and NEXACT® exhibit high stiffness and are self-locking even when powered down due to the clamping action of the piezo actuators in the mechanics. This entails nanometer position stability at rest, with no heat dissipation or servo-dither.

Controller and Drive Electronics Optimized for the Application

NEXACT® actuators require special drive electronics to control the complex stepping sequences. The E-860 series NEXACT® controllers are available in different open and closed-loop versions. For example, the E-861 includes a complete NEXACT® servo-controller with low-noise, 24-bit drivers and a powerful DSP. It also comes with ample software for easy integration and highly effective computer control. For applications which do not require the highest resolution lower-priced drive electronics, ranging all the way to OEM boards, can be ordered.

The products described in this document are in part protected by the following patents: German Patent No. P4408618.0

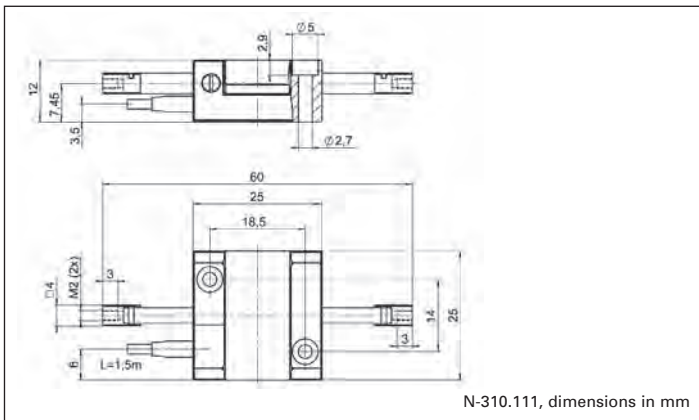
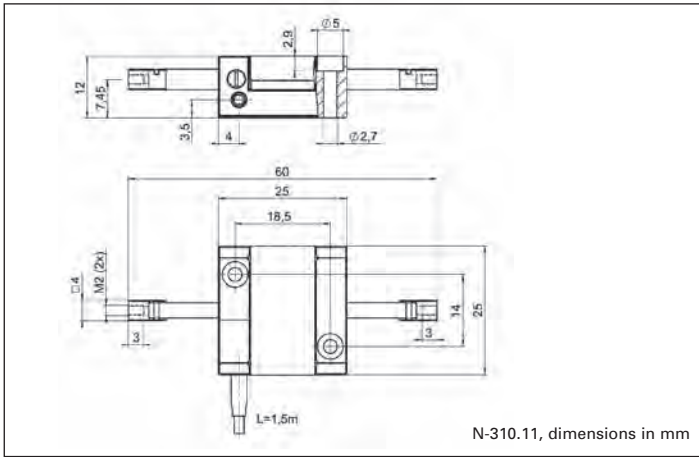

N-381 piezo stepper linear actuator for sample positioning and manipulation provides long travel, high speed and very high resolution



Translation stage with N-310 NEXACT® drive. The positioner offers 20 mm travel range with an encoder resolution of 25 nm

Technical Data

Model	N-310.11, N-310.111	Tolerance
Active axes	X	
Motion and positioning		
Travel range	20 mm	
Step size (in step mode)	5 nm to 5 µm	
Travel range in analog operation	7 µm	max.
Open-loop resolution	0.03 nm**	typ.
Step frequency	1.5 kHz*	max.
Max. speed	10 mm/s*	max.
Mechanical properties		
Push/Pull force (active)	10 N	max.
Drive properties		
Drive type	NEXACT® linear drive	
Operating voltage	-10 V to +45 V	
Miscellaneous		
Operating temperature range	0 to 50 °C	
Body material	Stainless steel, non-magnetic	
Mass	50 g	±5%
Cable length	1.5 m	±10 mm
Connector	HD Sub-D connector 15 pin, single channel	
Recommended controller/driver	E-860-series (see p. 1-20)	

*Depending on the control electronics.

**Depending on the drive electronics. 1 nm with E-861.



The N-661 miniature linear stage integrates a PiezoWalk® NEXACT® linear motor combined with a high-resolution linear encoder. It provides 20 mm travel and resolution down to the nanometer range.

N-381 NEXACT® Linear Actuator, Manipulator, Piezo Stepper

High-Resolution PiezoWalk® Linear Actuator with Optional Position Sensor

N-381 piezo stepper linear actuator for sample positioning and manipulation provides long travel, high speed and very high resolution; shown with E-861 NEXACT® Controller



- **Travel Range 30 mm**
- **Zero-Wear Piezo Stepping Drive, Ideal for Micro- and Nano-Manipulation**
- **Integrated Linear Encoder Option for Highest Accuracy with 20 nm Resolution**
- **Very High Acceleration, e.g. for Cell Penetration**
- **Two Operating Modes: Continuous Stepping Mode and Continuously Variable, High-Dynamics Analog Mode for 30 µm Resolution****
- **Up to 10 N Force Generation**
- **Self Locking at Rest, no Heat Generation**
- **Smooth Motion, no Closed-Loop Jitter**
- **Vacuum-Compatible and Non-Magnetic Versions**

The compact N-381 linear actuators are ideal drives and micro manipulators e.g. for biotechnology and nanotechnology applications. Rapid accelerations, velocities of 10 mm/s

and forces up to 10 N enable high-dynamics and throughput for automation tasks. The PiezoWalk® drive principle allows long travel ranges and fast oscillations of 7 µm amplitude with frequencies up to several 100 Hz. This “analog mode” can be used to provide rapid acceleration, e.g. in cell penetration applications, or smooth motion for dynamic laser tuning or even for active damping of oscillations. Two models are available: The N-381.3A model is equipped with a high-resolution position sensor, allowing sub-micrometer repeatability in closed-loop operation. The N-381.30 open-loop version is intended for high precision applications where the absolute position is

not important or is controlled by an external loop (video, laser, quadcell, etc.).

Piezo Stepping Drive—the Multi-Functional Piezo Linear Motor

A great advantage characteristic of the NEXACT® piezo stepping drive is its dual-mode operating principle combining the best features of other piezo motor designs, such as high resolution, high force and high speed into one compact unit. At the target position the drive requires no current and generates no heat while providing long-term, nanometer stability. This autolocking feature also completely eliminates servo-jitter as it occurs with other

Ordering Information

N-381.3A
NEXACTUATOR® Linear Actuator, 30 mm, 20nm Encoder Resolution

N-381.00
NEXACTUATOR® Linear Actuator, 30 mm, Open-Loop

Available on request

Ask about custom designs!

closed-loop motors. Since motion is not based on dynamic friction as with piezo inertial drives (stick-slip-motors) but solely caused by the nanometer precise motion of clamped piezo actuators, there is no wear to limit the lifetime. When operated in closed-loop, excellent velocity control is achieved.

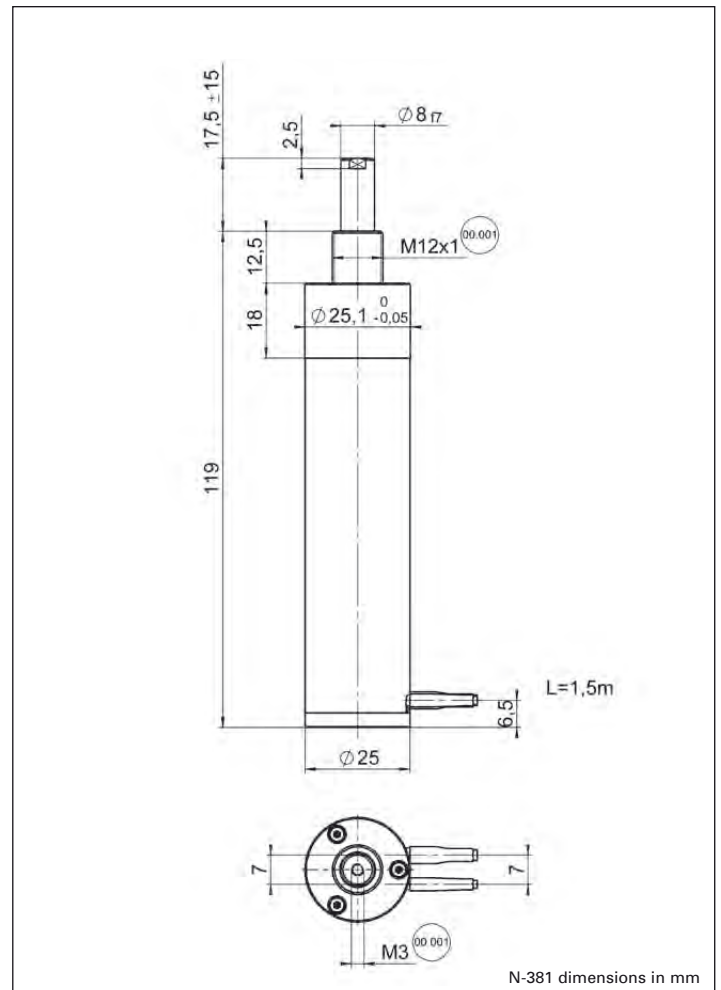

N-381 dimensions in mm

Application Examples

- Drive unit for scanning stage
- Cell manipulation, biohandling
- Micromanipulation
- Life science
- Photonics
- Laser tuning
- Motion in strong magnetic fields

Working Principle for Application Flexibility

NEXACT® PiezoWalk® technology overcomes the limitations of conventional nanopositioning drives and combines virtually unlimited travel ranges with high stiffness in a very small package. Furthermore, NEXACT® actuators provide piezo-class resolution (far below one nanometer) and millisecond responsiveness. The special drive design reduces the operating voltage to 45 V and below.

In operation, piezoceramic bending elements act on the runner, which is connected to the moving part of the application. The length of the runner determines the travel range

and can be chosen as required. To move the runner over longer distances the stepping mode is used, whereas for distances smaller than one step, the analog mode enables high-dynamics positioning with resolutions far below one nanometer.

Controllers and Drivers Optimized for the Application

NEXACT® actuators require special drive electronics to control the complex stepping sequences. The E-861 (see p. 1-20) includes a complete NEXACT® servo-controller with low-noise drivers and a powerful DSP. It also comes with ample software for easy integration and highly effective computer control. For applications which do not require the highest reso-

lution, the E-862 (see p. 3-10) lower-priced drive electronics, can be ordered.

The products described in this document are in part protected by the following patents:

German Patent No. P4408618.0

Index

Technical Data (Preliminary)

Model	N-380 Open-Loop	N-381 Closed-Loop
Active axes	X	X
Motion and positioning		
Travel range	30 mm	30 mm
Step size (in step mode)	0.1 to 15 µm	–
Integrated sensor	–	Incremental linear encoder
Sensor resolution	–	20 nm*
Travel range in analog mode	7 µm	7 µm
Open-loop resolution	0.03 nm**	0.03 nm**
Closed-loop resolution	–	20 nm*
Step frequency	0 to 800 Hz	–
Max. velocity	10 mm/s*	10 mm/s*
Mechanical properties		
Stiffness in motion direction	2.4 N/µm	2.4 N/µm
Max. push / pull force (active)	10 N	10 N
Max. holding force (passive)	15 N	15 N
Lateral force	10 N	10 N
Drive properties		
Drive type	NEXACT® linear drive	NEXACT® linear drive
Operating voltage	-10 V to +45 V	-10 V to +45 V
Miscellaneous		
Operating temperature range	0 to 50 °C	0 to 50 °C
Material	Stainless steel / CFRP	Stainless steel / CFRP
Mass	250 g	255 g
Cable length	1.5 m	1.5 m
Connector	15-pin HD-Sub-D connector, one channel	15-pin HD-Sub-D connector, one channel
Recommended controller/driver	E-860 series (see p. 1-20)	E-861.1A1 (see p. 1-20)

*With E-861. Depending on drive electronics.

**Depending on the drive electronics. 1 nm with E-861.

N-111 NEXLINE® OEM Linear Actuator

Nanopositioning Over Long Travel, PiezoWalk® Principle



N-111 compact OEM nanopositioning actuator. In principle the movement by piezo steps allows an infinite travel range

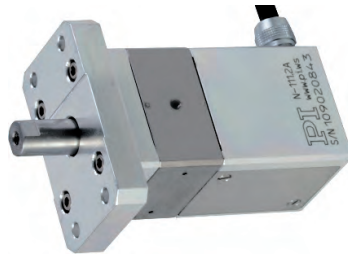

- Travel Range 10 mm
- Resolution to 0.025 nm Open-Loop, 5 nm Closed-Loop
- Up To 50 N Force Generation and 70 N Holding Force
- Self Locking at Rest, No Heat Generation
- Non-Magnetic and Vacuum-Compatible Working Principle
- Cleanroom Compatible

The innovative N-111 NEXLINE® OEM linear actuators are compact actuators for nanopositioning with travel ranges to 10 mm, high resolution, and generated forces to 50 N. The operating principle is based on coordinated motion of a number of highly preloaded linear and shear piezo elements acting on a runner. NEXLINE® drives thus combine long travel ranges with piezo-class pre-

cision. For closed-loop operation without an additional position sensor the N-111.2A is equipped with a linear encoder that provides 5 nm resolution over the full travel range. In open-loop operation position resolution down to 25 picometers can be achieved by use of a high-dynamics analog mode.

NEXLINE® Working Principle for Application Flexibility

NEXLINE® PiezoWalk® drives can be used wherever high loads must be positioned very precisely over long distances and then perhaps subjected to small-amplitude dynamic adjustment, as for active vibration control. By varying the combination of longitudinal and shear piezo elements, the step size, dynamic operating range (analog travel), clamping force, speed and stiffness can all be optimized for a particular application.

One Working Principle – Different Operating Modes

NEXLINE® PiezoWalk® drives overcome the limitations of conventional nanopositioning systems in their combination of long travel ranges and high resolution and stiffness. The piezoceramic clamping and shear elements act directly on a moving runner that is coupled to the moved object. While in full step mode the runner can be moved over larger distances with maximum velocity, nanostepping mode allows uniform motion with highly constant speed. In open-loop operation any position resolution may be achieved which only depends on the stability of the control signal. Analog operation over a distance of less than one step enables high-dynamics positioning with resolutions far below one nanometer.

Choice of Controllers for Optimization

NEXLINE® operation is supported by two motion controller models providing different features. The E-755 controller offers full functionality for nanometer precise positioning. The E-712 supplies more sophisticated linearization

Ordering Information

N-111.20
NEXLINE® OEM Piezo Stepping Actuator, 10 mm, 50 N

N-111.2A
NEXLINE® OEM Piezo Stepping Actuator, 10 mm, 50 N, Linear Encoder, 5 nm Resolution

Ask about custom designs!

algorithms resulting in very smooth motion with highly constant velocity. It can also provide higher speed with maximum force.

Patented Technology

The products described in this document are in part protected by the following patents:
German Patent No. 10148267
US Patent No. 6,800,984



Z / tip / tilt platform with NEXLINE® drives and position sensors; 300 mm (12") diameter, 200 N load capacity, 1.3 mm travel range, 10 mrad tilt range

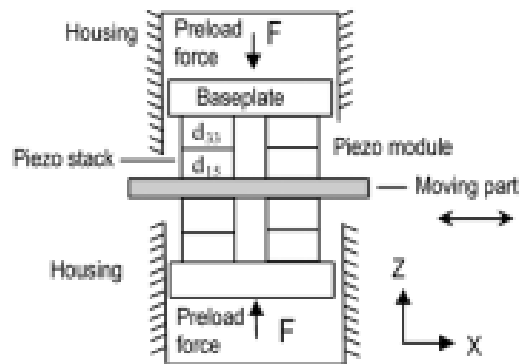

NEXLINE® linear actuator principle

Application Examples

- Semiconductor technology
- Semiconductor testing
- Wafer inspection
- Nano lithography
- Nano-imprinting
- Nanometrology
- Active vibration damping
- Motion in strong magnetic fields

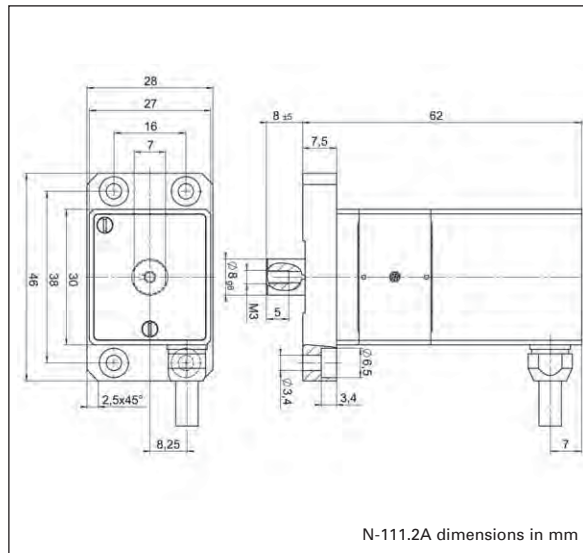
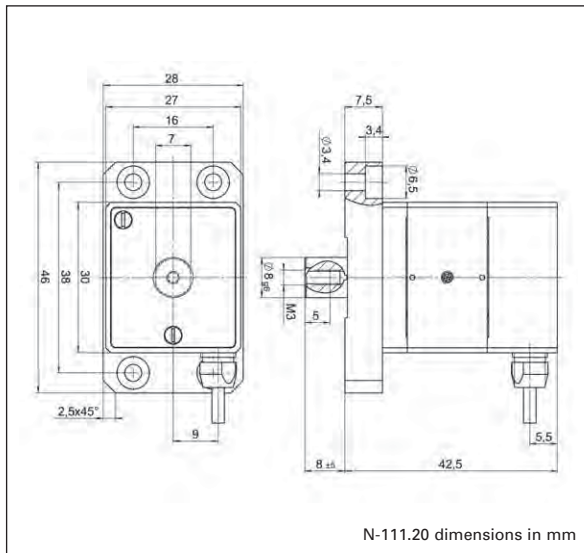

Technical Data

Model	N-111.20	N-111.2A	Tolerance
Active axes	X	X	
Motion and positioning			
Travel range	10 mm	10 mm	
Step size (in step mode)	10 nm to 7 µm	10 nm to 7 µm	
Travel range in analog mode	±2 µm	±2 µm	
Integrated sensor	–	Linear encoder	
Open-loop resolution	0.025 nm	0.025 nm	typ.
Closed-loop resolution	–	5 nm	
Max. velocity (10% duty cycle, full step mode)*	1.0 mm/s	1.0 mm/s	
Max. velocity (100% duty cycle, full step mode)*	0.6 mm/s	0.6 mm/s	
Max. velocity (100% duty cycle, nanostepping mode)**	0.4 mm/s	0.4 mm/s	
Mechanical properties			
Stiffness in motion direction	16 N/µm	16 N/µm	±20%
Drive force (active)***	50 N	50 N	max.
Holding force (passive)	70 N	70 N	min.
Drive properties			
Motor type	NEXLINE®	NEXLINE®	
Operating voltage	±250 V	±250 V	
Miscellaneous			
Operating temperature range	-40 to 80 °C	-40 to 80 °C	
Material	Aluminium stainless steel, titanium	Aluminium stainless steel, titanium	
Mass	245 g	325 g	
Cable length	1.5 m	1.5 m	±10 mm
Connector	Sub-D connector NEXLINE® single-channel	Sub-D connector NEXLINE® single-channel plus sensor connector	
Recommended controller	E-755,101, E-712	E-755.1A1, E-712	

* Depending on drive electronics. Data refer to operation together with E-712 controller.

** Depending on drive electronics. Data refer to operation together with E-712 controller. Together with the E-755 controller a velocity of up to 0.1 mm/s (closed-loop) and 0.2 mm/s (open-loop) can be achieved. The maximum speed in nanostepping mode is set so as to ensure the highest possible velocity constancy, with no speed fluctuations while steps are being performed.

*** Data refer to full step mode operation.

N-216 NEXLINE® Linear Actuator

High-Force PiezoWalk® Drive for Long-Range Nanopositioning

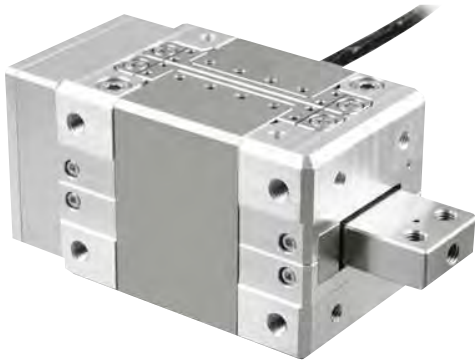

N-216 NEXLINE® High-Load Actuator. Feed motion is realized by piezo stepping motion which allows basically unlimited travel ranges with nanometer accuracy

- **Travel Range 20 mm**
- **Resolution to 0.03 nm Open-Loop, 5 nm Closed-Loop**
- **Up to 800 N Holding Force**
- **Self Locking at Rest**
- **Non-Magnetic and Vacuum-Compatible Working Principle**
- **Cleanroom Compatible**

N-216 NEXLINE® high-load linear actuators are ultra-precision nanopositioning actuators with travel ranges to 20 mm and push / pull forces to 600 N. The operating principle is based on coordinated motion of a number of highly preloaded linear and shear piezo elements acting on a runner. NEXLINE® drives combine long travel ranges with piezo-class precision.

N-216 comes in two versions for open- or closed-loop operation, as well as in two different load configurations. Closed-loop versions are equipped with a linear encoder for direct

position measurement of the moving runner. The encoder features 5 nm resolution over the full travel range. In open-loop operation a positioning resolution to 30 picometers can be realized by use of the high-dynamics analog operation mode.

Unlimited Lifetime

The application area of NEXLINE® drives often lies in the difficult-to-access internals of machines, where nanometer-realm adjustment and vibration cancellation are required. Long lifetime is therefore a basic requirement for NEXLINE® actuators. To promote long lifetime, the controller can reduce the operating voltage on all the piezo elements to zero at any position and still maintain the full holding force.

One Working Principle – Different Operating Modes

NEXLINE® PiezoWalk® drives overcome the limitations of conventional nanopositioning systems in their combination of long travel ranges and high resolution and stiffness. The piezo-ceramic clamping and shear

elements act directly on a moving runner that is coupled to the moved object. While in full step mode the runner can be moved over larger distances with maximum velocity, nanostepping mode allows uniform motion with highly constant speed. In open-loop operation any position resolution may be achieved which only depends on the stability of the control signal. Analog operation over a distance of less than one step enables high-dynamics positioning with resolutions far below one nanometer.

Choice of Controllers for Optimization

NEXLINE® operation is supported by two motion controller models providing different features. The E-755 controller offers full functionality for nanometer precise positioning. The E-712 supplies more sophisticated linearization algorithms resulting in very smooth motion with highly constant velocity. It can also provide higher speed with maximum force.

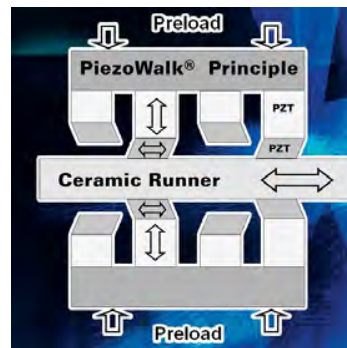

6-axis parallel-kinematic nanopositioning system (Hexapod) with N-215 based NEXLINE® high-load actuators for use in strong magnetic fields

Ordering Information

N-216.10
NEXLINE® Piezo Stepping High-Load Actuator, 20 mm, 300 N, Open-Loop

N-216.1A
NEXLINE® Piezo Stepping High-Load Actuator, 20 mm, 300 N, Linear Encoder, 5 nm Resolution

N-216.20
NEXLINE® Piezo Stepping High-Load Actuator, 20 mm, 600 N, Open-Loop

N-216.2A
NEXLINE® Piezo Stepping High-Load Actuator, 20 mm, 600 N, Linear Encoder, 5 nm Resolution

Ask about custom designs!

Patented Technology

The products described in this document are in part protected by the following patents:
German Patent No. 10148267
US Patent No. 6,800,984

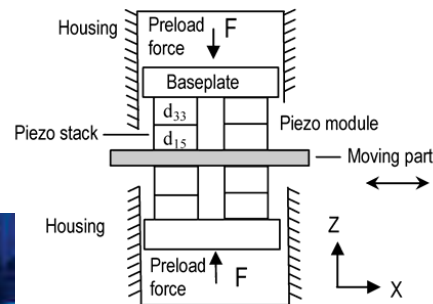

NEXLINE® linear actuator principle

Application Example

- Semiconductor technology
- Semiconductor testing
- Wafer inspection
- Nano lithography
- Nano-imprinting
- Nanometrology
- Active vibration damping
- Motion in strong magnetic fields

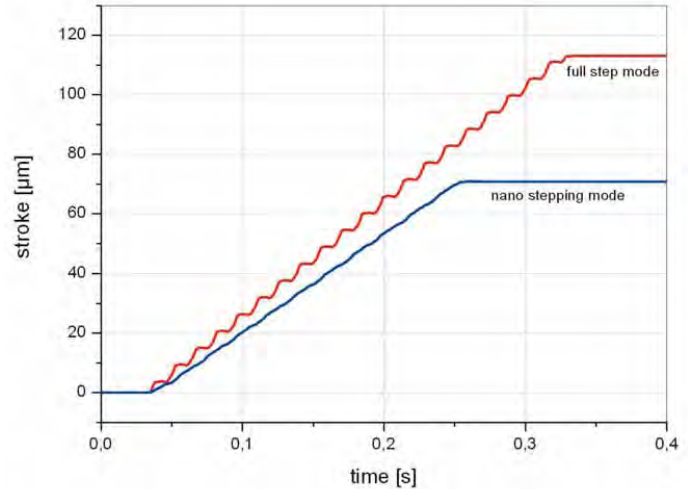
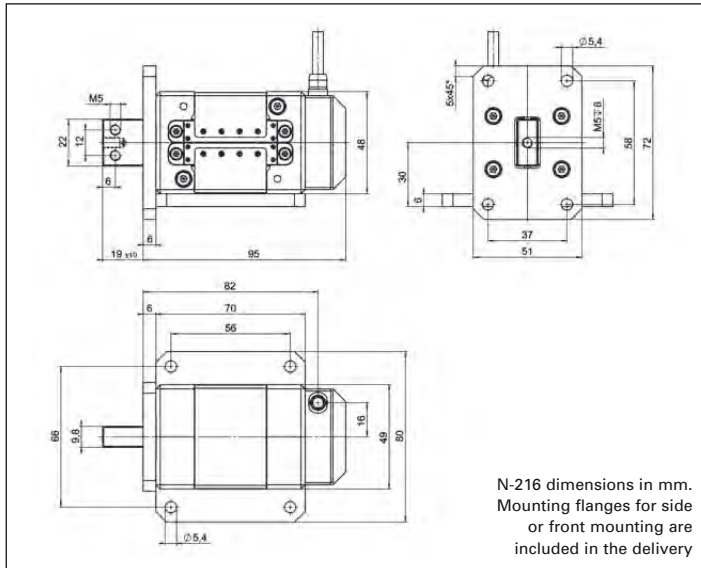

Motion mode comparison of a NEXLINE® actuator: The nanostepping mode provides a very smooth motion. Full step mode allows higher speed

Technical Data

Model	N-216.10 / N-216.1A	N-216.20 / N-216.2A	Tolerance
Active axes	X	X	
Motion and positioning			
Displacement	20 mm	20 mm	
Step size (in step mode)	10 nm to 10 µm	10 nm to 10 µm	
Travel range in analog mode	±3 µm	±3 µm	
Integrated sensor	N-216.10: none N-216.1A: linear encoder	N-216.20: none N-216.2A: linear encoder	
Open-loop resolution	0.03 nm	0.03 nm	typ.
Closed-loop resolution	- / 5 nm (N-216.1A)	- / 5 nm (N-216.2A)	
Max. velocity (10% duty cycle, full step mode)*	1.0 mm/s	1.0 mm/s	
Max. velocity (100% duty cycle, full step mode)*	0.6 mm/s	0.6 mm/s	
Max. velocity (100% duty cycle, nanostepping mode)**	0.4 mm/s	0.4 mm/s	
Mechanical properties			
Drive force (active)***	300 N	600 N	max.
Holding force (passive)	400 N	800 N	min.
Drive properties			
Motor type	NEXLINE®	NEXLINE®	
Operating voltage	±250 V	±250 V	
Miscellaneous			
Operating temperature range	-40 to 80 °C	-40 to 80 °C	
Material	Aluminum, stainless steel	Aluminum, stainless steel	
Mass	1150 g	1250 g	
Cable length	2.0 m	2.0 m	
Connector	Sub-D connector NEXLINE® single-channel N-216.1A: plus sensor connector	Sub-D connector NEXLINE® single-channel N-216.2A: plus sensor connector	
Recommended controller	E-755, E-712	E-755, E-712	

* Depending on drive electronics. Data refer to operation together with E-712 controller.

** Depending on drive electronics. Data refer to operation together with E-712 controller. Together with the E-755 controller a velocity of up to 0.1 mm/s (closed-loop) and 0.2 mm/s (open-loop) can be achieved. The maximum speed in nanostepping mode is set so as to ensure the highest possible velocity constancy, with no speed fluctuations while steps are being performed.

*** Data refer to full step mode operation.

Ultrasonic Piezo Motor Basics

PILine® Ultrasonic Piezomotors – Working Principle

PILine® linear piezomotors are based on a novel, patented ultrasonic drive developed by PI. At the heart of the system is a rectangular monolithic piezoceramic plate (the stator), segmented on one side by two electrodes. Depending on the desired direction of motion, the left or right electrode of the piezoceramic plate is excited to produce high-frequency eigenmode oscillations at tens to hundreds of kilohertz. An alumina friction tip (pusher) attached to the plate moves along an inclined linear path at the eigenmode frequency.

Through its contact with the friction bar, it provides micro-impulses that drive the moving part of the mechanics (slider, turntable, etc.) forward or backwards. With each oscillatory cycle, the mechanics executes a step of a few nanometers; the macroscopic result is smooth motion with a virtually unlimited travel range. The driving force is taken from the energy in the longitudinal oscillation component. The transverse component serves to increase / decrease the pressure of the friction tip against the friction bar. The transverse oscillation energy determines the maximum frictional force and hence the holding and driving force of the motor. State-of-the-art ultrasonic motors can produce

accelerations to 10 g and velocities to 500 mm/s.

Ultrasonic motors cannot provide the unlimited resolution of linear piezo actuators and flexure-guided piezo positioning stages. These motors transfer motion through friction, which is why their repeatability is limited to about 50 nm. Much higher resolution and holding forces can be achieved with PiezoWalk® piezomotors / drives.

PILine® Levels of Integration

PILine® ultrasonic drive products are offered in three different levels of integration. The drive electronics and controller can be chosen accordingly.

- P-661 and P-664 OEM motors require the greatest amount of care at the customer's site. Motor and friction bar – the length depends on the travel range – have to be integrated into a mechanical setup. Operation requires preload of the motor against the friction bar, guiding and, if necessary, the servo-loop.

- M-674 RodDrives can replace classical drive elements like rotary motor / leadscrew assemblies, or magnetic linear drives integrated into a micropositioner or handling device. Integration requires guiding and – if necessary – the servo-loop.



Variety of PILine® ultrasonic piezomotors, translation stages and motion controllers.

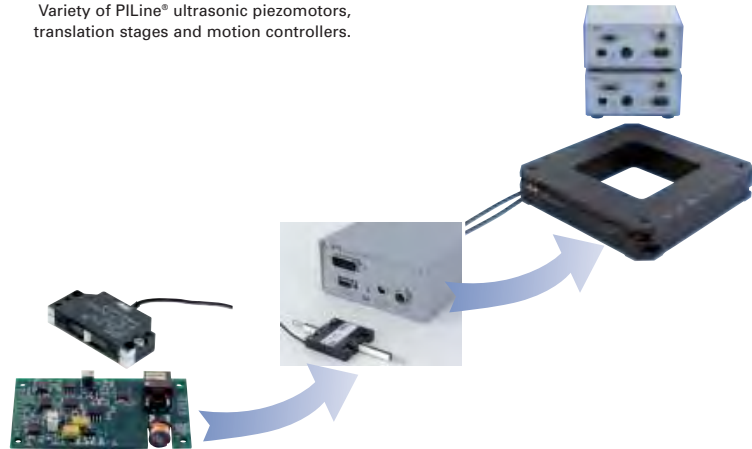

PILine® levels of integration: OEM motor, RodDrive, linear positioning stage.

- Linear positioning stages represent the highest level of manufacturer integration. The piezomotor is integrated completely in a high-quality mechanical setup including if necessary the servo-loop with direct-metrology linear encoders.

PILine® ultrasonic motors are based on a simple construction allowing for the design of low-cost drive units and extremely compact, high-speed micro-positioning stages smaller than a matchbox.

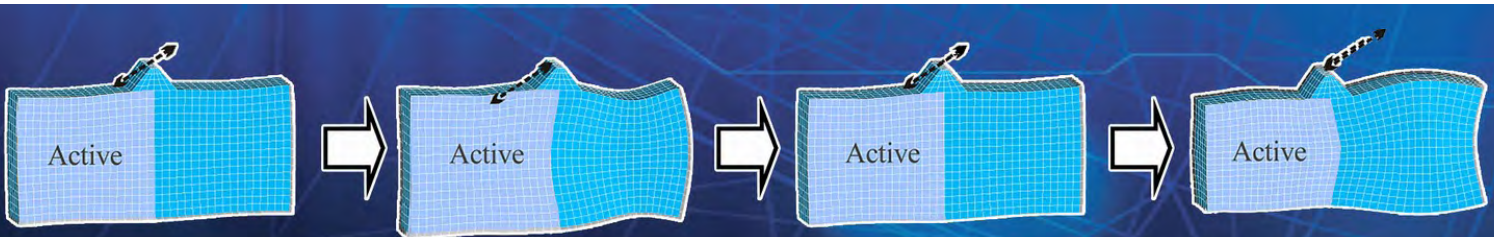

Ultrasonic Piezo Motor Basics

Features and Advantages of PILine® Ultrasonic Piezomotors

- **Compact Size:** the direct-drive principle allows the design of ultra-compact translation stages. The M-662, for example, provides 20 mm travel in a 28 x 28 x 8 mm package.
- **Low inertia, high acceleration, speed and resolution:** PILine® drives achieve velocities to 500 mm/s and accelerations to 10 g. They are also very stiff, a prerequisite for their fast step-and-settle times – on the order of a few milliseconds – and provide resolution to 0.05 μm . The lack of a leadscrew means no lubricant flow or material relaxation to cause sub-micron creep. There is also no rotational inertia to limit acceleration and deceleration.
- **Excellent Power-to-Weight Ratio:** PILine® drives are optimized for high performance in a minimum package. No comparable drive can offer the same combination of acceleration, speed and precision.
- **Safe:** The minimum inertia of the moving platform together with the “slip clutch” effect of the friction drive provide better protection of precision fixtures / devices than leadscrew-driven stages. Despite the high speeds and accelerations, there is a much lower risk of pinching fingers or other injuries than with conventional drives. This means users may not need interlocks, light curtains or other measures to keep them safe.
- **Self-Locking Feature:** PILine® drives create a braking force when not energized without the position shift common with conventional mechanical brakes. Other benefits of the self-locking are the elimination of servo dither and

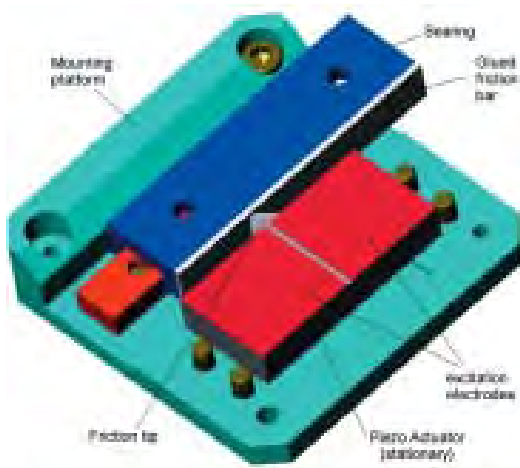

Principle design of a PILine® ultrasonic piezomotor-driven translation stage.

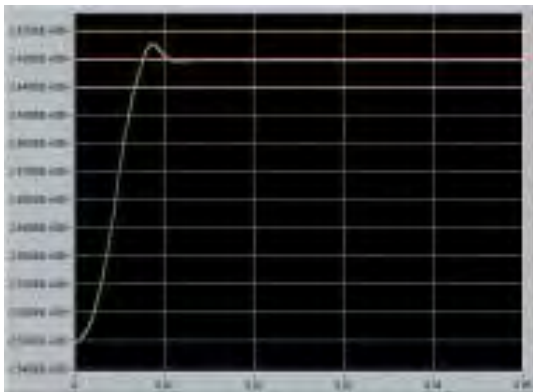

Settling behavior of a PILine® M-663 linear stage, 100 μm step. A stable position to within 0.1 μm can be reached in only 10 ms.



steady-state heat dissipation.

- **Vacuum Compatibility:** Vacuum compatible versions of PILine® drives are available.
- **Negligible EMI:** PILine® drives do not create magnetic fields nor are they influenced by them, a decisive advantage in many applications.
- **Custom Solutions / Flexibility for OEMs:** PILine® drives are available in open-loop and closed-loop translation stages and as OEM components. PI develops and manufactures all piezo ceramic components in-house. This gives us the flexibility to provide custom motors (size, force, environmental conditions) for OEM and research applications.
- **Quality, Lifetime, Experience:** Based on PI's 30+ years of experience with piezo nanopositioning technology, PILine® drives offer exceptional precision and reliability with an MTBF of >20,000 hours. Rotating components such as gears, shafts and moving cables that are prone to failure in conventional motion systems, are not part of the PILine® design.

Custom high-force ultrasonic piezo motors can provide forces to 50N.



U-164 PLine® Piezo Linear Drive

Fast, Compact OEM Ultrasonic Linear Motor



OEM ultrasonic piezo linear motor
U-164.01

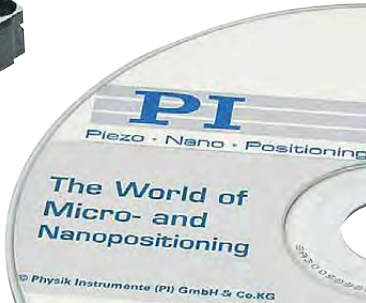

- **Patented Principle Features with High Forces in Small Space**
- **Easy Mounting**
- **Max. Velocity 500 mm/s**
- **Acceleration up to 5 g**
- **Min. Incremental Motion to 0,05 µm**
- **Self Locking, Push-/Pull Forces to 4 N**
- **No Electro-Magnetic Fields**
- **Integrated Actuators & Positioning Systems Also Available**

PILine® Linear Motors—Small, Fast, Highly Effective

Despite their small size, PILine® linear motors generate high driving and holding forces. PILine® piezo motors have a new, patented, ultrasonic drive

Application Examples

- Biotechnology
- R&D
- Semiconductor testing
- Mass storage device testing
- Metrology
- Micromanipulation
- Microscopy
- Photonics packaging
- Quality assurance testing

developed by PI. The core piece of the system is a piezoceramic plate, which is excited with high-frequency eigenmode oscillations. A friction tip attached to the plate moves along an inclined linear path at the eigenmode frequency. Through its contact with the friction bar, the moving part of the mechanics drives forward or backwards. With each oscillatory cycle, the mechanics executes a step of a few nanometers; the macroscopic result is smooth motion with a virtually unlimited travel range.

High Speed and Acceleration

PILine® piezomotor drives can provide accelerations of up to 5 g and speeds of up to 500 mm/s, together with high resolution and high holding force. Because the ceramic

stator is pressed against the slider, holding forces are generated when the motor is powered down. The result is very high position stability without the heat dissipation common in conventional linear motors.

Accessories for Easy Integration

The PILine® motors require a special drive electronics to generate the ultrasonic oscillations for the piezoceramic element. The drive electronics is available as OEM board, stand-alone device or integrated inside a controller and therefore not included in the delivery. PI offers friction bars with different lengths.

Long Lifetime

PI has over 30 years experience with piezo technology and nanopositioning. PILine® drives offer high precision and reliability. This is because PILine® piezo linear motor drives have no mechanical components such as shafts and gears which can cause failures in conventional motors.

Ordering Information

U-164.01
PILine® Piezo Linear Motor, 4 N

Accessories:

P-664.B01
Friction Bar for PILine® Miniature Linear Piezomotor, 15 mm

P-664.B02
Friction Bar for PILine® Miniature Linear Piezomotor, 25 mm

P-664.B05
Friction Bar for PILine® Miniature Linear Piezomotor, 55 mm

C-184.164
Analog OEM Driver Board for PILine® Motors

C-185.164
Analog Stand-Alone Drive Electronics with Power Supply for PILine® Motors

Controllers for closed-loop operation are available as C-867 (see p. 4-116).

Ask about custom designs!

Patent Information

The products described in this document are in part protected by the following patents:
US Pat. No. 6,765,335
German Patent No. 10154526

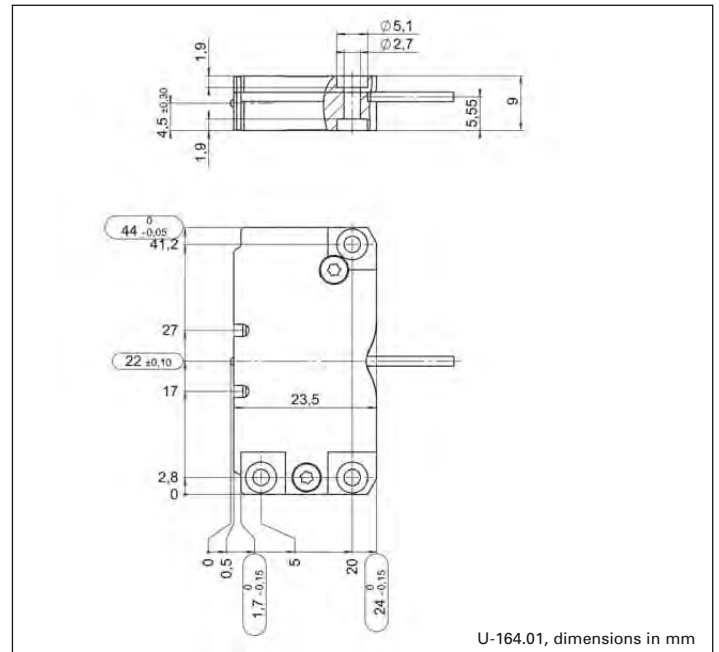

Technical Data (preliminary)

Model	U-164.01	Unit	Tolerance
Motion and positioning			
Displacement	unlimited*	mm	
Minimum incremental motion, open-loop	0.05**	μm	typ.
Max. velocity	500	mm/s	
Mechanical properties			
Stiffness when powered down	3	N/μm	±10 %
Holding force when powered down	3	N	Max.
Push / pull force	4	N	Max.
Preload on friction bar	18	N	±10 %
Drive properties			
Resonant frequency	155	kHz	typ.
Motor voltage	60 (RMS)	V	
Operating voltage driver electronics	12	V	
Max. el. power consumption driver	10	W	
Miscellaneous			
Operating temperature range	-20 to +50	°C	
Body material	Al (black anodized)		
Mass	0.02	kg	±5 %
Cable length	1.0	m	±10 mm
Connector	Open leads		
Recommended controller/driver	C-184.164 OEM board C-185.164 in box		

*The travel range of piezo linear motors is virtually unlimited and depends on the length of the friction bar, which is available separately.

**The minimum incremental motion is a typical value that can be achieved in the open-loop mode of a piezomotor stage. To reach the specifications it is important to follow the mounting guidelines of the OEM-motors.

P-653 PLine® Miniature Linear Motor / Slide

Ultrasonic OEM Drive for High Volume Applications

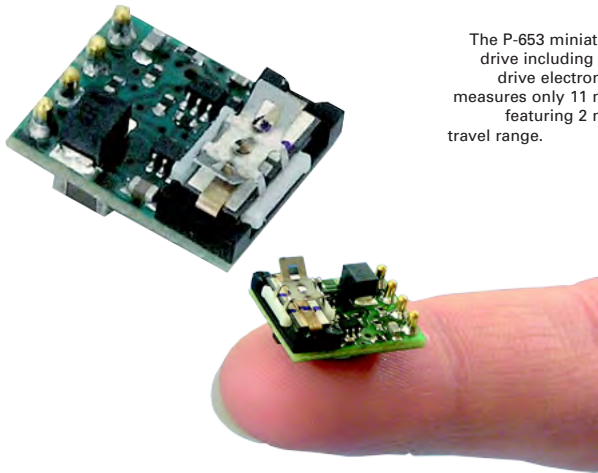

The P-653 miniature drive including the drive electronics measures only 11 mm featuring 2 mm travel range.

- True Linear Motor Slide / No Rotary Conversion Losses
- Cost-Effective OEM Drive for High Quantity-Applications
- Preassembled and Mounted on a PCB Board
- Very Compact: Piezomotor Drive is Only 8 mm Long
- Fast Response: Full Stroke in <50 ms
- Force Generation to 0.15 N
- Self Locking at Rest
- Travel Range 2 mm, Velocity up to 200 mm/s

P-653 PLine® OEM piezomotor drives are ideal for OEM applications where space is limited and moved masses are small. These tiny linear positioners can be used to replace classical drive elements like miniaturized motor/spindle systems or other linear motors, which P-653 outclasses with its speed of up to 200 mm/s. PLine® piezo linear motors offer a number of advantages over classical drives:

- High velocities
- Compact design
- High push/pull and holding forces relative to the drive size

Integration of the P-653 in an application is simple because the moving slider and the piezo actuator are delivered assembled as a unit and already mounted on a PCB board. Drive electronics is included on the same board and requires a supply voltage of only 5 VDC.

Mechanical mounting is thus facilitated as well: All that remains is to affix the payload to the slider.

The motors are designed for moving small objects such as optical fibers, optics, micro- or electro-mechanical elements fast and precisely.

Working Principle

P-653 drives employ a new, patented, ultrasonic piezomotor drive developed by PI. The highly compact, integrated piezomotor can attain velocities of up to 200 mm/s together with high position resolution and—considering its length of only 8 mm—a high holding force. Because the ceramic stator is pressed against the slider, piezomotor drives resist motion with an intrinsic holding force when the unit is at rest. The result is very high position stability, without the heat dissipation common with conventional linear motors. During operation, the oscillating piezoceramic propels the slider over the length of the motor. There are no gears, leadscrews or other mechanical components to contribute play or backlash.

Simple Control

The high-frequency, nanometer level oscillations (~500 kHz) needed by the PLine® motors are created by driver electronics, which self-adjusts to the resonant frequency of the motor ceramic, meaning that no individual tuning is necessary. The driver electronics can in turn be controlled by short voltage pulses.

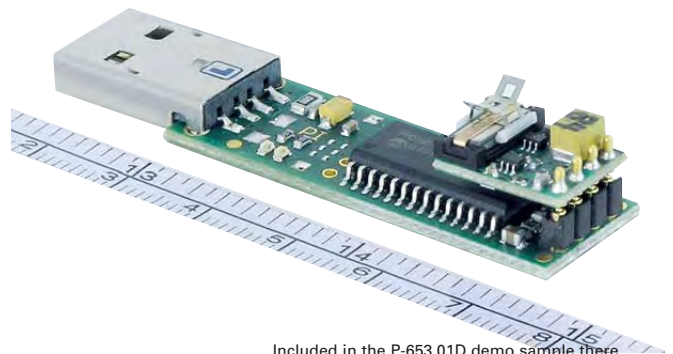

Included in the P-653.01D demo sample there is the P-653.01 OEM drive together with additional electronics featuring an USB interface

Order Information

- P-653.01**
Miniatur PLine® OEM Drive, 2 mm Travel Range, 0.15 N, mounted on PCB board
- P-653.01D**
Miniature PLine® OEM Drive, 2 mm Travel Range, 0.15 N, Demo Sample Kit with USB Interface

Ask about custom designs

Note

The products described in this document are in part protected by the following patents:
German Patent
No. 102004059429
International Patent
No. WO2006/027031A1

Application Examples

- Consumer electronics
- Miniature mechatronics
- Micromanipulation
- Micropositioning
- Toys

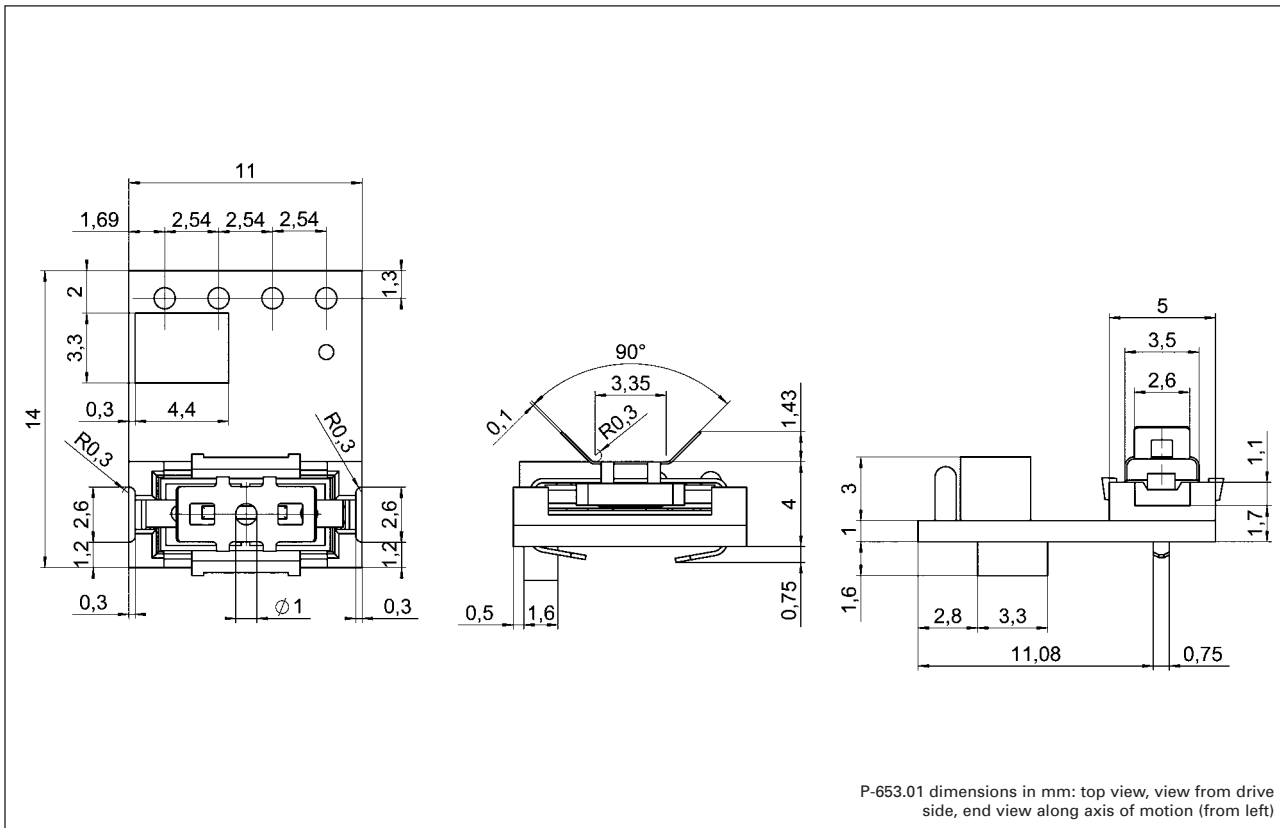

Technical Data

P-653.01	
Motion and positioning	
Travel range	2 mm
Step size at 0.25 ms ON time	5 to 15 μ m
Step size at 1.0 ms ON time	20 to 120 μ m
Max. velocity*	100 to 200 mm/s
Typ. velocity**	50 to 90 mm/s
Mechanical properties	
Holding force when powered down	0.3 N
Max. push / pull force	0.15 N
Drive properties	
Resonant frequency (typ.)	515 kHz
Integrated piezo motor	PILine® P-653
Operating voltage (drive electronics)	5 VDC
Current consumption incl. drive electronics	0.1 A
Control voltage	5 V TTL
Miscellaneous	
Operating temperature range	-40 to 85 °C
Mass	1 g \pm 5%
Connectors	Header pin sockets
Recommended driver	Piezomotor drive electronics included
Dimensions	15 x 11 x 8 mm incl. drive electronics
Lifetime	>5,000,000 cycles

All data refer to 100% duty cycle.

* without load. @ 5 g: 80 to 140 mm/s; @ 10 g: 50 to 100 mm/s

** without load.

M-674 Ceramic Ultrasonic Motor Actuators

PILine® RodDrive Integrated Piezo Linear Motor Drive



The M-674 PILine® RodDrive, shown with C-184 OEM and C-185 bench-top driver electronics, provides 7 N pushing force and travel ranges of 50, 100 and 150 mm



- **Drive-Component for Integration into Micropositioning Systems**
- **Travel Ranges to 150 mm**
- **Push/Pull Forces to 7 N**
- **Min. Incremental Motion to 0.05 µm**
- **Velocity to 450 mm/s**
- **Self-Locking at Rest**

M-674 PILine® RodDrives represent a level of integration between PILine® OEM piezo linear motors such as P-664 and guided micropositioning systems such as the M-682 series stages. RodDrives may replace classical drive elements like rotary motor/leadscrew assemblies, or magnetic linear drives integrated into a micropositioner.

Application Examples

- System Integration for Micropositioning Products
- Automation
- Handling
- Micromanipulation
- Biotechnology
- Metrology

They consist of a rod which is preloaded by piezo linear motors from two sides. Depending on the way of integration, either the rod or the motor block is coupled to the moving platform.

Advantages of PILine® Micropositioning Systems

The ultrasonic piezoceramic drives used in PILine® micropositioners have a number of advantages over classical drives:

- Higher Accelerations, up to 10 g
- Speeds up to 500 mm/s
- Small Form Factor
- Self-Locking When Powered Down
- No Shafts, Gears or Other Rotating Parts
- Non-Magnetic and Vacuum Compatible Drive Principle

Working Principle

RodDrives employ a patented ultrasonic drive developed by PI. The highly compact, integrated P-664 piezomotors can provide velocities of 450 mm/s, together with high resolution and holding force. The maximum travel is determined by the length of the rod and is basically unlimited. Customized adaptations in terms of operating and holding force are feasible by varying type and number of motors used. Because the integrated ceramic motors are preloaded against the rod, RodDrives resist motion with an intrinsic holding force when at rest. The result is very high position stability without the heat dissipation common with conventional linear motors. Furthermore, there are no gears, leadscrews or other mechanical components to contribute play or backlash.

Variety of Drivers / Controllers

PILine® piezomotors require a drive electronics for exciting the ultrasonic oscillations. The drive electronics is available as OEM board, stand-alone device or integrated inside a closed-loop motion controller and therefore not included in the delivery.

Ordering Information

- M-674.164**
PILine® RodDrive, 50 mm, 7 N
- M-674.264**
PILine® RodDrive, 100 mm, 7 N
- M-674.364**
PILine® RodDrive, 150 mm, 7 N

Closed-Loop Operation: Optimized for High Velocity and Rapid Step/Settling

Together with a position sensor, RodDrives can be operated in closed-loop with the C-866.D64 piezo motor controller. This specialized servo-controller also integrated the motor drive electronics and enables highly constant speeds up to 350 mm/s with very short settling times (10's of msec). RodDrives can also be operated with conventional servo-controllers. In this case, the C-185 (to be ordered separately) external drive electronics is required which accepts a ±10 V analog signal from the controller.

Note

The products described in this document are in part protected by the following patents:
US-Pat. No. 6,765,335

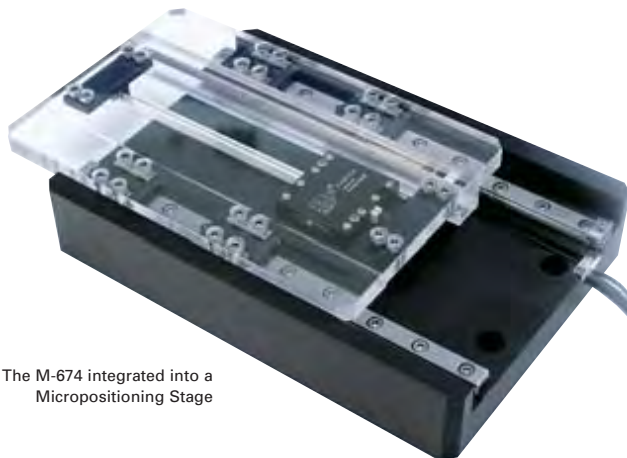

The M-674 integrated into a Micropositioning Stage

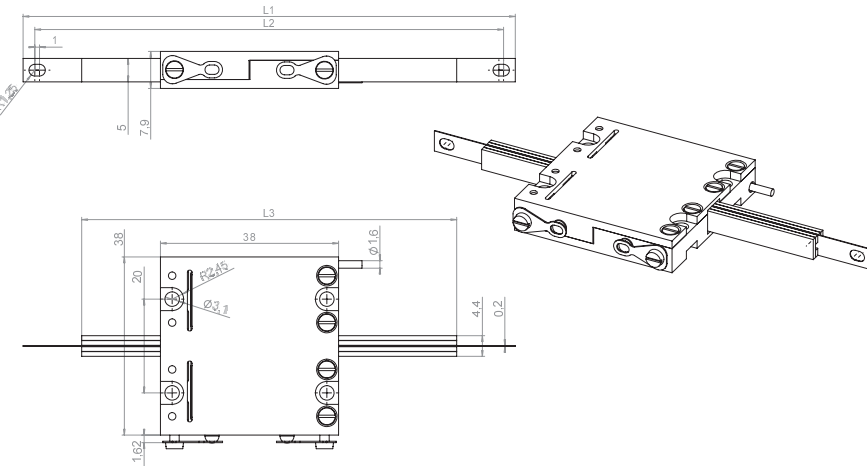

Dimensions of the M-674.00 RodDrive in mm

Maß	M-674.164	M-674.264	M-674.364
L1	105	155	205
L2	100	150	200
L3	80	130	180

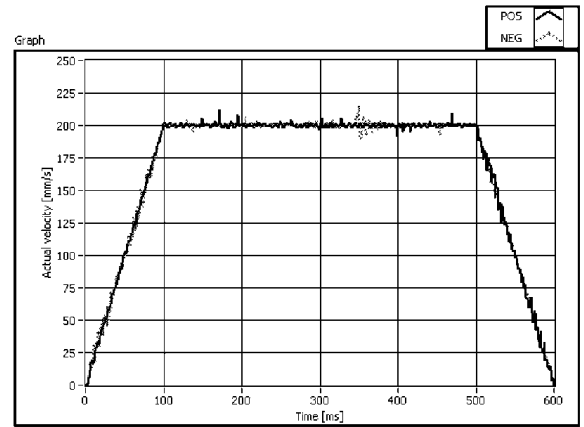

Constancy of closed-loop velocity at 200 mm/s of an integrated M-674 RodDrive

Technical Data

Models	M-674 M-674.164	M-674 M-674.264	M-674 M-674.364	Units	Tolerance
Motion and positioning					
Travel range	50	100	150	mm	x
Minimum incremental motion, open-loop	0.05*	0.05*	0.05*	µm	typ.
Max. velocity	450	450	450	mm/s	
Max. acceleration	20	20	20	m/s	
Mechanical properties					
Stiffness when powered down	5**	5**	5**	N/µm	±10 %
Holding force when powered down	7	7	7	N	max.
Push / pull force	7	7	7	N	max.
Drive properties					
Resonant frequency	155	155	155	kHz, typ.	
Integrated piezo motor	2 x P-Line® P-664 (Dual Motor)	2 x P-Line® P-664 (Dual Motor)	2 x P-Line® P-664 (Dual Motor)		
Motor voltage range	200 (peak-peak)*** 70 (RMS)***	200 (peak-peak)*** 70 (RMS)***	200 (peak-peak)*** 70 (RMS)***	V	
Operating voltage drive electronics	12	12	12	V	
Max. elec. power consumption drive electronics	15	15	15	W	
Miscellaneous					
Operating temperature range	-20 to +50	-20 to +50	-20 to +50	°C	
Body material	PEEK-PTFE	PEEK-PTFE	PEEK-PTFE		
Mass	0.1	0.12	0.14	kg	±5 %
Cable length	1.5	1.5	1.5	mm	±10 mm
Connector	LEMO connector	LEMO connector	LEMO connector	LEMO connector	
Recommended controller/driver	C-184.D64 OEM drive electronics board C-185.D64 driver C-866.D64 Controller for closed-loop operation	C-184.D64 OEM drive electronics board C-185.D64 driver C-866.D64 Controller for closed-loop operation	C-184.D64 OEM drive electronics board C-185.D64 driver C-866.D64 Controller for closed-loop operation		

* The minimum incremental motion is a typical value that can be achieved in the open-loop mode of a piezomotor stage. To reach the specs it is important to follow the mounting guidelines of the OEM-motors.

** Stiffness at 25 °C.

*** The operating voltage is supplied by the drive electronics.

M-664 Ceramic Ultrasonic Motor Linear Slide

Low-Profile High-Speed PLine® Translation Stage with Linearencoder



Fast and compact M-664 piezo translation stage with linear encoder

- Travel Range 25 mm
- Max. Velocity 400 mm/s
- Ultra-Low Profile, 15 mm
- Direct Metrology Linear Encoder with 0.1 μm Resolution
- High Guiding Accuracy with Crossed Roller Bearings
- Compact XY Combinations
- Piezo Linear Motor with 6 N Drive Force
- Self Locking at Rest

M-664 micropositioning systems are low-profile, high-accuracy translation stages with piezo linear encoders. The M-664 stage is next-larger in the series of piezomotor-driven stages of which the M-663 is the smallest.

Application Examples

- Biotechnology
- Micromanipulation
- Microscopy
- Quality assurance testing
- Metrology
- Mass storage device testing
- R&D
- Photonics packaging

For improved guiding accuracy, the M-664 uses two crossed roller bearings mounted on ground aluminum profiles. The integrated P-664 PLine® linear motor can generate forces up to 6 N and maximum closed-loop velocities to 400 mm/s over a 25 mm travel range.

Advantages of PLine® Micropositioning Systems

The ultrasonic piezoceramic drives used in PLine® micropositioners have a number of advantages over classical drives:

- Higher Accelerations, up to 10 g
- Speeds up to 500 mm/s
- Small Form Factor
- Self-Locking When Powered Down

- No Shafts, Gears or Other Rotating Parts
- Non-Magnetic and Vacuum-Compatible Drive Principle

Optimized Controller and Drive Electronics

PLine® motors require a special drive electronics to generate the ultrasonic oscillations for piezoceramic element. For optimum performance the highly specialized C-866 motion controller is recommended. This sophisticated controller also integrates the drive electronics. Furthermore, the controller has a number of special features, including dynamic parameter switching for an optimized high-speed motion and settling behavior to take into account the motion characteristics typical of piezomotors. The broad-band encoder input (35 MHz) supports the outstanding high accelerations and velocities of

Ordering Information

M-664.164
PLine® Micro Positioning Stage with P-664 Piezo Linear Motor, 25 mm, 6 N
Ask about custom designs!

PLine® drives at high resolutions.

Optionally, for use with third party servo controllers, the C-185 analog drive electronic (stand-alone unit) is available. It controls the motor speed by an analog ±10 V signal. For optimum performance this driver must be tuned together with the stage and should be ordered at the same time as the motor/stage.

Notes

The products described in this document are in part protected by the following patents:
US Pat. No. 6,765,335
German Patent No. 10154526

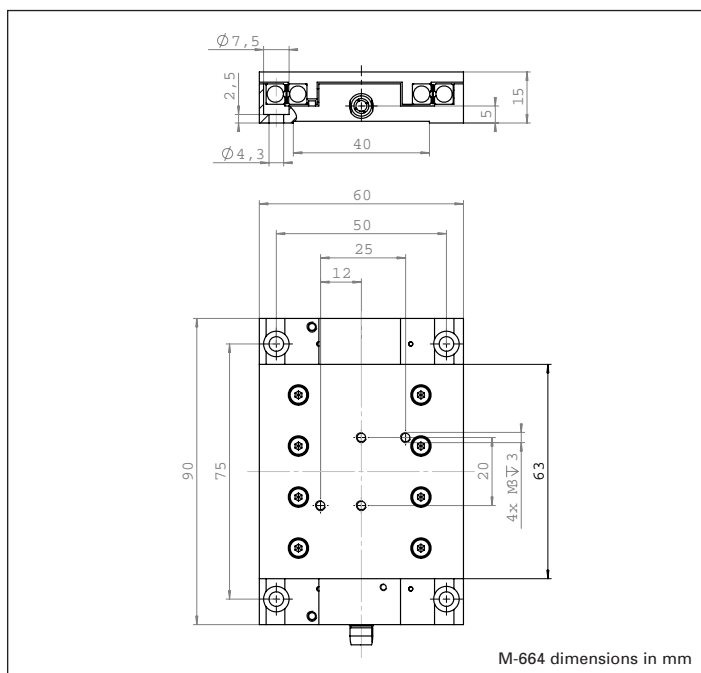



PILine® Micropositioning stages: M-682, M-664 and M-663 (from left)

Technical Data

Models	M-664.164	Tolerance
Active axes	X	
Motion and positioning		
Travel range	25 mm	
Integrated sensor	Linear encoder	
Sensor resolution	0.1 μm	
Min. incremental motion	0.1 μm	typ.
Backlash	$\pm 0.2 \mu\text{m}$	typ.
Unidirectional repeatability	0.2 μm	typ.
Pitch	$\pm 50 \mu\text{rad}$	typ.
Yaw	$\pm 50 \mu\text{rad}$	typ.
Max. velocity	400 mm/s	
Reference switch repeatability	1 μm	typ.
Mechanical properties		
Max. load	25 N	
Max. push/pull force	6 N	
Max. holding force	4 N	
Drive properties		
Motor type	P-664 PILine® ultrasonic piezo drive	
Operating voltage	168 V (peak-to-peak) * 60 V (RMS) *	
Electrical power	10 W **	nominal
Current	800 mA **	
Limit and reference switches	Hall-effect	
Miscellaneous		
Operating temperature range	-20 to +50 °C	
Material	Al (black anodized)	
Dimensions	90 x 60 x 15 mm	
Mass	0.190 kg	$\pm 5\%$
Cable length	1.5 m	$\pm 10 \text{ mm}$
Connector	MDR, 14-pin	
Recommended controller/driver	C-866.164 single-axis controller/driver C-185.164 drive electronics	



M-692 XY combinations are only 28 mm high. Shown here are custom vacuum versions of the M-692.1U4 (20 mm) and M-692.2U4 (90 mm)



The total height of M-692 micropositioning stages with ultrasonic piezo linear motors is outstandingly low

* The stage supply power is drawn from the drive electronics, which runs on 12 V.

** For drive electronics

P-601 Piezo Flexure Linear Actuator

PiezoMove® High-Precision, High-Speed, Flexure-Guided Lever-Amplified Z-Actuator

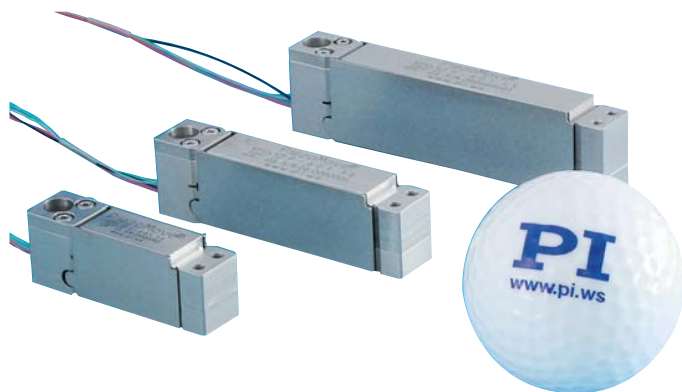

P-601 PiezoMove® Lever Amplified Z-Actuators.

- Flexure Guidance for Frictionless, Ultra-Straight Motion
- Standard Travel Ranges to 480 µm, Custom to 1 mm
- Very Fast Response, to 250µsec Feasible, Resolution to 0.2 nm
- High Dynamics and Stiffness
- PICMA® High-Performance Piezo Actuators
- Open and Closed-Loop Versions
- Ideal for OEM Applications

Lever amplified PiezoMove® P-601 actuators combine large vertical travel ranges up to 480 µm and a high positioning accuracy in a very compact design. With settling times of only a few milliseconds and a resolution in the sub-nanometer range they are well suited for static and dynamical applications.

PiezoMove® P-601 lever amplified actuators cover the range between direct-driven pre-loaded piezo translators, such as the P-840 series, and single-axis nanopositioning stages, like the P-611 series. Compared to direct-driven piezo transla-

tors, lever amplified actuators offer larger travel ranges, a much higher lateral stiffness and guiding precision. Compared to single-axis nanopositioning stages, they offer clearly smaller dimensions. PiezoMove® lever amplified actuators feature a resolution to 0.2 nm and a repeatability to 8 nm.

With their highly precise, frictionless flexure guidance, a very high stiffness and excellent straightness of motion are reached. Together with their small dimensions and the cost-effective design, the P-601 lever amplified actuators are especially suited for OEM applications. Versions with strain-gauge sensors (SGS) are equipped with a full bridge circuit that is insensitive to thermal drift. Versions without a sensor are also available for open-loop applications. In addition to standard models made from steel special versions from Invar or aluminum,

as well as non-magnetic ones are available on request.

Superior Lifetime

Reliability is assured by the use of award-winning PICMA® multilayer actuators, which are integrated into a sophisticated, single-module, flexure guiding system. The PICMA® actuators feature cofired ceramic encapsulation and thus offer better performance and reliability than conventional piezo actuators. The wire-EDM-cut flexures are FEA modeled to make them extremely precise. In addition they are maintenance-free and not subject to wear. [c](#)

Ordering Information

- P-601.1S**
PiezoMove® Lever Amplified Actuator, 100 µm, SGS
- P-601.3S**
PiezoMove® Lever Amplified Actuator, 250 µm, SGS
- P-601.4S**
PiezoMove® Lever Amplified Actuator, 400 µm, SGS
- P-601.10**
PiezoMove® Lever Amplified Actuator, 110 µm, Open-Loop
- P-603.30**
PiezoMove® Lever Amplified Actuator, 300 µm, Open-Loop
- P-601.40**
PiezoMove® Lever Amplified Actuator, 480 µm, Open-Loop

Application Example

- Nanopositioning
- Semiconductor Testing
- Adaptronics
- Photonics / Integrated Optics
- Biotechnology

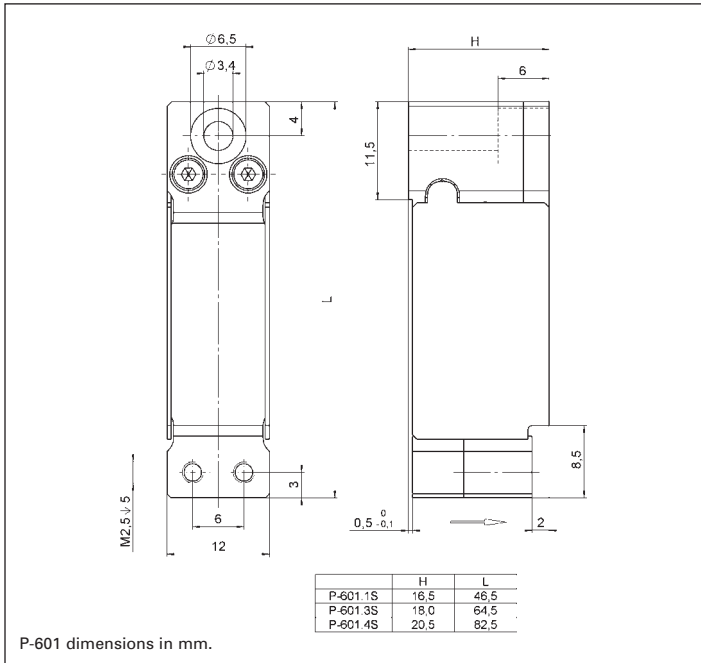

Technical Data

Models	P-601.10	P-601.1S	P-601.30	P-601.3S	P-601.40	P-601.4S	Units	Tolerances
Active Axis	Z	Z	Z	Z	Z	Z		
Motion and Positioning								
Integrated sensor	–	SGS	–	SGS	–	SGS		
Travel range -20 to +120 V, open-loop	110	110	300	300	480	480	µm	min.
Travel range closed-loop	–	100	–	250	–	400	µm	
Resolution open-loop	0.2	0.2	0.3	0.3	0.4	0.4	nm	typ.
Resolution closed-loop	2	2	6	6	12	12	nm	typ.
Linearity	–	0.1	–	0.3	–	0.3	%	typ.
Unidirectional repeatability	–	8	–	10	–	30	nm	typ.
Pitch	20	20	20	20	20	20	µrad	typ.
Yaw	10	10	10	10	10	10	µrad	typ.
Mechanical Properties								
Stiffness in motion direction	0.8	0.8	0.38	0.38	0.28	0.28	N/µm	±20 %
Resonant frequency unloaded	750	750	440	440	350	350	Hz	±20 %
Resonant frequency loaded (30 g)	620	620	350	350	290	290	Hz	±20 %
Push-/pull force in motion direction	30/10	30/10	20/10	20/10	15/10	15/10	N	Max.
Lateral force	30	30	30	30	30	30	N	Max.
Drive Properties								
Drive type	PICMA®	PICMA®	PICMA®	PICMA®	PICMA®	PICMA®		
Electrical capacitance	1.5	1.5	3.1	3.1	4.6	4.6	µF	±20 %
DOOC	1.9	1.9	1.6	1.6	1.4	1.4	µA/(Hz x µm)	±20 %
Miscellaneous								
Operating temperature range	-20 to 80	-20 to 80	-20 to 80	-20 to 80	-20 to 80	-20 to 80	°C	
Material	Stainless Steel	Stainless Steel	Stainless Steel	Stainless Steel	Stainless Steel	Stainless Steel		
Mass	50	50	75	75	110	110	g	±5 %
Cable length	250	250	250	250	250	250	mm	±10 mm
Sensor connection	Open leads	Open leads	Open leads	Open leads	Open leads	Open leads		
Voltage connection	Open leads	Open leads	Open leads	Open leads	Open leads	Open leads		
Recommended driver/controller	A, G	D, H	A, G	D, H	A, G	D, H		

P-602 PiezoMove Flexure Actuator with High Stiffness

Integrated Guiding System, High Force and Large Travel Ranges



P-602 linear actuator family featuring travel ranges of 100, 500, and 1000 μm (from left to right)

- Frictionless Flexure Guiding System for Straight Motion
- Integrated Motion Amplifier for Travel Ranges to 1 mm
- High Dynamics and Stiffness, Forces to 400 N, Backlash-Free Construction
- Outstanding Lifetime Due to PICMA® Piezo Actuators
- Available with Integrated Position Sensor
- Custom Designs with Larger Travel or Faster Response and Non-Magnetic Versions Feasible
- Ideal for OEM-Applications in Adaptronics, Biotechnology or Microfluidics

P-602 PiezoMove flexure-guided piezo actuators integrate a frictionless high-efficiency motion amplifier to combine large travel ranges up to 1 millimeter

Application Examples

- Nanopositioning
- Adaptronics
- Active vibration control
- Nano-imprinting
- Active Tool control
- Laser technology
- Semiconductor technology
- Active and adaptive optics

with high stiffness and very fast response. They do not contain any components that require maintenance or are subject to wear or tear. The flexure guides eliminate tip motion permitting only for a very slight tilt at the drive head. This design feature saves the cost for additional guiding systems when integrating these actuators in applications for the active control of tools, vibrations or deformations for accuracies down to a few 10s of nanometers.

Options and Custom Versions

For OEM applications, PiezoMove actuators can be modified in various ways to suit the customer's requirements. The

Ordering Information

PiezoMove® OEM Linear Actuator with High Stiffness

- 1 Travel Range 100 μm
- 3 Travel Range 300 μm
- 5 Travel Range 500 μm
- 8 Travel Range 1000 μm

- P-602.
- 00 Open-loop
 - S0 SGS Sensor
 - SL SGS Sensor, LEMO Connector

PiezoMove® OEM Linear Actuators with High Force

- 1 Travel Range 100 μm
- 3 Travel Range 300 μm
- 5 Travel Range 500 μm

- P-602.
- 08 Open-loop
 - S8 SGS Sensor
 - L8 SGS Sensor, LEMO Connector

Ask about custom designs!

stiffness and force generation can be influenced via the lever design and the dimensions of the piezo ceramics used in the actuator. If only a small force and low guiding accuracy are required, large strokes of several 100 μm and high frequencies can be achieved with small actuators, e.g. for micropump drives. For high-accuracy applications, an integrated position feedback sensor is available. The actuators were designed to allow for considerable cost savings in large production runs.

OEM Control Electronics

PI also supplies a variety of controllers to match the actuators. These range from simple amplifier modules (see p. 2-164) and analog closed-loop OEM controllers (see p. 2-110)

to high-performance digital controllers (see p. 2-100ff). The great choice of actuators and controllers allows customers to select the optimum combination of performance and cost for their application.

Ceramic-Insulated Piezo Actuators Provide Superior Lifetime

The highest possible reliability is assured by employing the award-winning PICMA® multi-layer piezo actuators. PICMA® actuators are the only actuators on the market with a ceramic-only insulation which makes them resistant to ambient humidity and leakage-current failures. They are thus far superior to conventional actuators in reliability and lifetime.

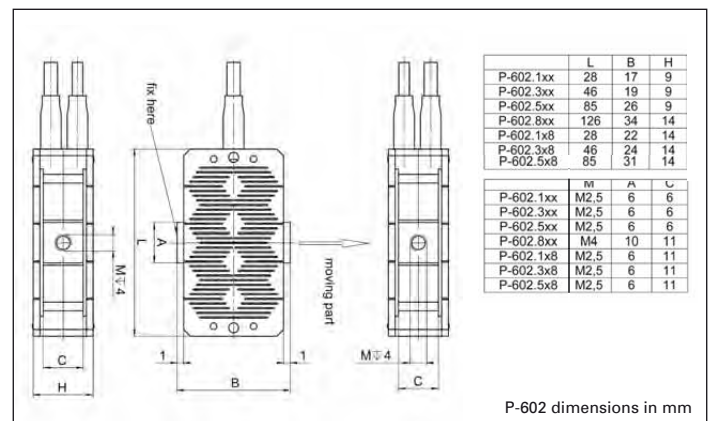

P-602 dimensions in mm



PI offers a large variety of standard and custom lever-amplified piezo actuators for almost any application

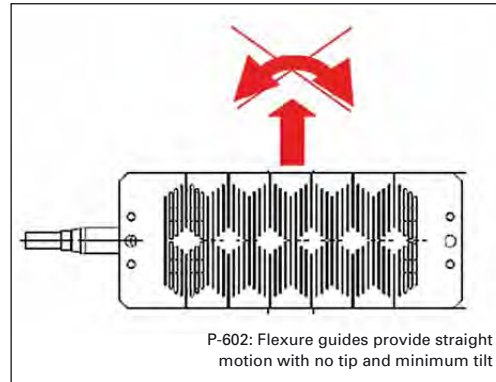

Technical Data (preliminary)

Model	P-602.100 P-602.1S0 P-602.1SL	P-602.300 P-602.3S0 P-602.3SL	P-602.500 P-602.5S0 P-602.5SL	P-602.108 P-602.1S8 P-602.1L8	P-602.308 P-602.3S8 P-602.3L8	P-602.508 P-602.5S8 P-602.5L8	P-602.800 P-602.8S0 P-602.8SL	Units	Tolerance
Active axes	X	X	X	X	X	X	X		
Motion and positioning									
Integrated sensor	- / SGS / SGS	- / SGS / SGS	- / SGS / SGS	- / SGS / SGS	- / SGS / SGS	- / SGS / SGS	- / SGS / SGS		
Open-loop travel, -20 to +120 V	120	300	600	100	300	500	1000	μm	min. (+20%/0)
Closed-loop travel	- / 100 / 100	- / 300 / 300	- / 500 / 500	- / 100 / 100	- / 300 / 300	- / 500 / 500	- / 1000 / 1000	μm	
Open-loop resolution	0.2	0.3	0.4	0.2	0.3	0.4	0.5	nm	typ.
Closed-loop resolution	- / 2 / 2	- / 3 / 3	- / 3 / 3	- / 2 / 2	- / 3 / 3	- / 3 / 3	- / 7 / 7	nm	typ.
Linearity, closed-loop	- / 0.5 / 0.5	- / 0.5 / 0.5	- / 0.5 / 0.5	- / 0.5 / 0.5	- / 0.5 / 0.5	- / 0.5 / 0.5	- / 1.5 / 1.5	%	typ.
Repeatability	- / 10 / 10	- / 20 / 20	- / 35 / 35	- / 10 / 10	- / 20 / 20	- / 35 / 35	- / 60 / 60	nm	typ.
Mechanical properties									
Stiffness in motion direction	0.8	0.35	0.3	2.3	0.75	0.65	0.4	N/μm	± 20%
Unloaded resonant frequency	1000	450	230	1000	450	230	150	Hz	± 20%
Blocking force	80	105	150	230	225	325	400	N	max.
Drive properties									
Ceramic type	PICMA® P-885	PICMA® P-885	PICMA® P-885	PICMA® P-888	PICMA® P-888	PICMA® P-888	PICMA® P-888		
Electrical Capacitance	1.5	3.1	6.2	6	13	26	39	μF	± 20%
Dynamic operating current coefficient	1.9	1.3	1.6	7.5	5	6	4	μA/(Hz•μm)	± 20%
Miscellaneous									
Operating temperature range	-20 to 80	-20 to 80	-20 to 80	-20 to 80	-20 to 80	-20 to 80	-20 to 80	°C	
Material	Stainless steel	Stainless steel	Stainless steel	Stainless steel	Stainless steel	Stainless steel	Stainless steel		
kg	28 x 17 x 9	46 x 19 x 9	85 x 26 x 9	28 x 22 x 14	46 x 24 x 14	85 x 31 x 14	126 x 34 x 14	mm	
Mass	0.022	0.04	0.105	0.05	0.088	0.215	0.355	kg	± 5%
Cable length	0.5 / 0.5 / 2	0.5 / 0.5 / 2	0.5 / 0.5 / 2	0.5 / 0.5 / 2	0.5 / 0.5 / 2	0.5 / 0.5 / 2	0.5 / 0.5 / 2	m	± 10 mm
Sensor / voltage connection	0- and S-version: open leads SL-version: LEMO connector	0- and S-version: open leads SL-version: LEMO connector	0- and S-version: open leads SL-version: LEMO connector	0- and S-version: open leads L-version: LEMO connector	0- and S-version: open leads L-version: LEMO connector	0- and S-version: open leads L-version: LEMO connector	0- and S-version: open leads SL-version: LEMO connector		

Recommended controller / amplifier

E-610 controller / amplifier see p. 2-110, E-625 bench-top controller see p. 2-114

P-603 PiezoMove Linear Actuator

Low-cost and with Large Travel Ranges



P-603 linear actuators with 500 and 100 μm travel range (from left to right). CD for size comparison

- Frictionless, High-Precision Flexure Guiding System
- Travel Ranges to 500 μm
- Cost-Effective Design
- Outstanding Lifetime Due to PICMA® Piezo Actuators
- Available with Integrated Position Sensor
- Ideal OEM Actuators for Precision Motion Control in Optics, Medical, Biotech and Microfluidics Applications
- Custom Designs with Larger Travel or Faster Response and Non-Magnetic Versions Feasible

P-603 PiezoMove flexure-guided piezo actuators integrate a frictionless high-efficiency motion amplifier to combine large

travel ranges up to 500 μm with high stiffness and very fast response. The flexure guides reduce tip at the drive head to a minimum saving the cost for additional guiding systems when integrating these actuators in micro-dispensing devices, pumps or servo valves. The overall precision of 10s of nanometers also makes these devices ideal for nanomanipulation applications.

Application Example

- Nanopositioning
- CCD / CMOS camera technology / Micro scanning
- Cell manipulation, biohandling
- Medical technology
- Micropumps
- Micro-dispensing
- Slit width adjustment
- Cavity Tuning
- Beam stabilization
- Photonics / integrated optics
- Switches

Options and Custom Versions

For OEM applications, PiezoMove actuators can be modified in various ways to suit the customer's requirements. The stiffness and force generation can be influenced via the lever design and the dimensions of the piezo ceramics used in the actuator. If only a small force and low guiding accuracy are required, large strokes of several

100 μm and high frequencies can be achieved with small actuators, e.g. for micropump drives. For high-accuracy applications, an integrated position feedback sensor is available. The actuators were designed to allow for considerable cost savings in large production runs.

OEM Control Electronics

PI also supplies a variety of controllers to match the actuators. These range from simple amplifier modules (see p. 2-164) and analog closed-loop OEM controllers (see p. 2-110) to high-performance digital controllers (see p. 2-100ff). The great choice of actuators and controllers allows customers to select the optimum combination of performance and cost for their application.

Increased Lifetime Through Humidity Resistance

The monolithic ceramic-encapsulated design provides better humidity protection than polymer-film insulation. Diffusion of water molecules into the insulation layer is greatly reduced by the use of cofired, outer ceramic encapsulation. Due to their high resonant frequency the actuators are suitable for highly dynamic applications with small loads; depending on the load an external preload for

Ordering Information

PiezoMove® OEM Linear Actuator with High Stiffness

- 1 Travel Range 100 μm
- 3 Travel Range 300 μm
- 5 Travel Range 500 μm

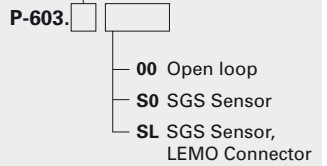

Ask about custom designs!

dynamic applications is recommended. The high Curie temperature of 320° gives PICMA® actuators a usable temperature range extending up to 150 °C, far beyond 80°C as is common for conventional multilayer actuators. With conventional multilayer actuators, heat generation – which is proportional to operating frequency – either limits the operating frequency or duty cycle in dynamic operation, or makes ungainly cooling provisions necessary. At the low end, operation down to a few Kelvin is possible (with reduced travel range).

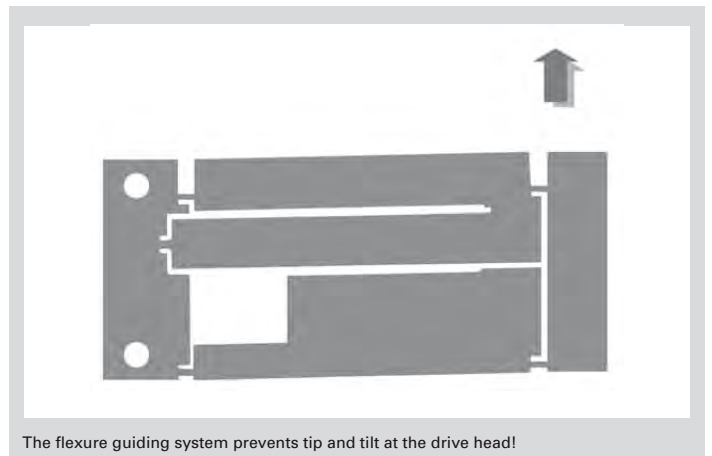

The flexure guiding system prevents tip and tilt at the drive head!



Levels of Integration: From Stack Actuator to 6-Axis Stage

	Stack actuators	Lever-amplified actuators	Positioning systems
Travel ranges	up to approx. 150 μm	up to 1 mm	up to 2 mm
Axes moved	one	one	up to three linear axes and three tip/tilt axes
Sensors	SGS optional	SGS optional	SGS or direct measuring capacitive sensors
Linearity	up to 99.8 %	up to 99.8 %	over 99.9 %
Guidance	none	flexures for rotations <10°	flexures for rotations <2°
Space required	low	low	depends on features
Price	low	low	depends on features
Integration effort	high	low	low

Flexure guided, lever-amplified actuators form a reasonably priced and easily integrated class of products between conventional piezo stack actuators and the complex piezo nanopositioning systems

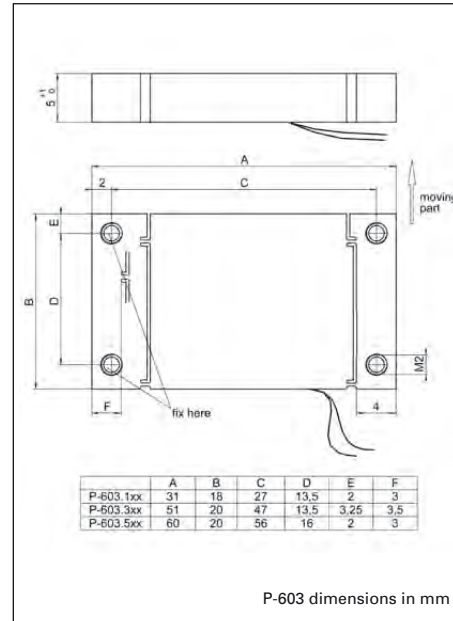

Technical Data (preliminary)

Model	P-603.1S0 P-603.1SL	P-603.3S0 P-603.3SL	P-603.5S0 P-603.5SL	P-603.x00 open-loop versions	Units	Tolerance
Active axes	X	X	X	X		
Motion and positioning						
Integrated sensor	SGS	SGS	SGS	–		
Open-loop travel, -20 to +120 V	100	300	550	as P-603.xS0	μm	min. (+20%/-0)
Closed-loop travel	100	300	500	–	μm	calibrated
Open-loop resolution	0.2	0.3	0.4	as P-603.xS0	nm	typ.
Closed-loop resolution	2	4	7.5	–	nm	typ.
Linearity, closed-loop	0.3	0.3	0.3	–	%	typ.
Repeatability	8	10	30	–	nm	typ.
Mechanical properties						
Stiffness in motion direction	0.25	0.14	0.06	as P-603.xS0	N/ μm	$\pm 20\%$
Unloaded resonant frequency	900	450	300	as P-603.xS0	Hz	$\pm 20\%$
Blocking force	20	35	25	as P-603.xS0	N	max.
Drive properties						
Ceramic type	PICMA® P-885	PICMA® P-885	PICMA® P-885	PICMA® P-885		
Electrical Capacitance	1.5	3.1	3.7	as P-603.xS0	μF	$\pm 20\%$
Dynamic operating current coefficient	1.9	1.3	1.6	as P-603.xS0	$\mu\text{A}/(\text{Hz}\cdot\mu\text{m})$	$\pm 20\%$
Miscellaneous						
Operating temperature range	-20 to 80	-20 to 80	-20 to 80	-20 to 80	°C	
Material	Stainless steel	Stainless steel	Stainless steel	Stainless steel		
Dimensions	31x18x5	50x20x5	51x20x5	as P-603.xS0	mm	
Mass	0.02 / 0.031	0.032 / 0.043	0.038 / 0.049	as P-603.xS0	kg	$\pm 5\%$
Cable length	0.5	0.5	0.5	0.5	m	± 10 mm
Sensor / voltage connection	S-version: open leads SL-version: LEMO connector (SGS Sensor)	S-version: open leads SL-version: LEMO connector (SGS Sensor)	S-version: open leads SL-version: LEMO connector (SGS Sensor)	Open leads		

Recommended controller / amplifier

E-610 controller / amplifier see p. 2-110, E-625 bench-top controller see p. 2-114

P-783 Piezo Flexure Linear Actuator

Piezoelectric Z-Nanopositioning Stage / Actuator with Direct Metrology Sensor

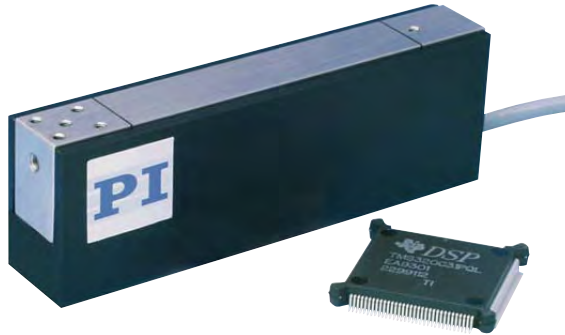

P-783 nanopositioning stage, microprocessor shown for size comparison

- Z-Travel to 300 μm
- Low Profile
- Frictionless Precision Flexure Guiding System
- Internal Motion Amplifier
- Closed-Loop Resolution <10 nm
- PICMA® High-Performance Piezo Drives

Long Travel Range

The P-783 piezo nano-Z-axis stage is a compact, closed-loop actuator providing a positioning and scanning range of up to 300 μm . It is designed for applications with loads ranging from a few grams to a few hundred grams.

Direct-Metrology LVDT Sensor

P-783 stages feature direct-measuring, non-contact LVDT sensors (direct metrology). Unlike indirect sensors, direct-metrology sensors measure

Application Examples

- Metrology
- Wafer inspection
- PCB inspection
- Nanopositioning
- Switching
- Biotechnology
- Micromanipulation

Ordering Information

P-783.ZL
Vertical Piezo Flexure Stage,
300 μm , LVDT Sensor

Ask about custom designs!

the actual distance between the fixed frame and the moving part of the stage. This results in higher motion linearity, long-term stability, phase fidelity, and—because external disturbances are seen by the sensor immediately—a stiffer, faster-responding servo-loop. See p. 2-4 ff. and p. 5-2 ff. for more information.

Working Principle / Reliability

P-783 nanopositioning stages are equipped with the award winning PICMA® piezo drives, integrated into a sophisticated flexure guiding system. The wire-EDM-cut flexures are FEA

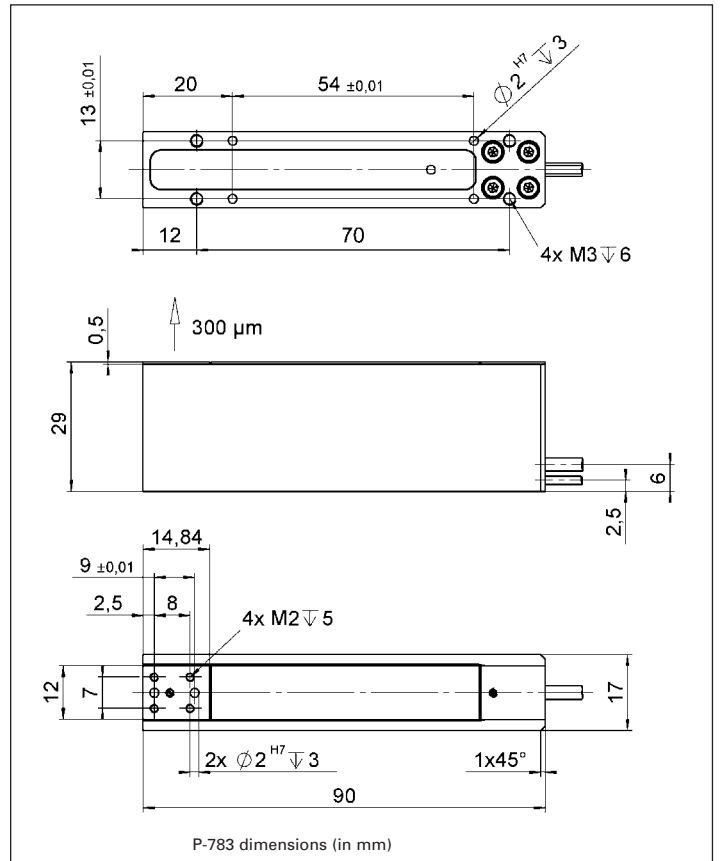

modeled for zero stiction, zero friction and exceptional guiding precision. The ceramic-encapsulated PICMA® drives are more robust than conventional piezo actuators, featuring superior lifetime and performance in both dynamic and static applications.

Because guidance, actuators and sensors are all frictionless and maintenance-free, these nanopositioning systems achieve outstanding levels of reliability.

Notes

See the “Piezo Drivers & Nanopositioning Controllers” section, p. 6-8 *ff.* for our comprehensive line of low-noise control electronics.

See the “Selection Guide” on p. 2-14 *ff.* for comparison with other nanopositioning systems.

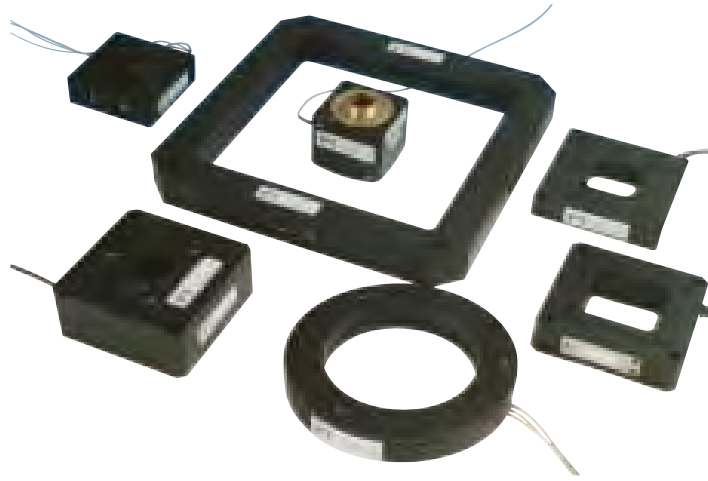

Variety of piezo flexure nanopositioning systems.
Call your PI Sales Engineer about your application.

Technical Data

Models	P-783.ZL	Units	Notes see p. 2-84
Active axes	Z		
Open-loop travel @ 0 to 100 V	300	$\mu\text{m} \pm 20\%$	A2
Closed-loop travel	300	μm	A5
Integrated feedback sensor	LVDT		B
* Closed-loop / open-loop resolution	10 / 1	nm	C1
Closed-loop linearity (typ.)	0.1	%	
Full-range repeatability (typ.)	± 15	nm	C3
Stiffness	0.15	$\text{N}/\mu\text{m} \pm 20\%$	D1
Push / pull force capacity (in operating direction)	20 / 10	N	D3
Max. normal load	+20 / -5	N	D4
Lateral force limit	0.5	N	D5
Lateral runout (tip/tilt) (typ.)	10 / 25	μrad	E1
Electrical capacitance	5.4	$\mu\text{F} \pm 20\%$	F1
** Dynamic operating current coefficient (DOCC)	2	$\mu\text{A}/(\text{Hz} \times \mu\text{m})$	F2
Unloaded resonant frequency	300	$\text{Hz} \pm 20\%$	G2
Resonant frequency @ 24 g load	240	$\text{Hz} \pm 20\%$	G3
Resonant frequency @ 100 g load	160	$\text{Hz} \pm 20\%$	G3
Operating temperature range	-20 to 80	$^{\circ}\text{C}$	H2
Voltage connection	VL		J1
Sensor connection	L		J2
Weight (with cables)	160	$\text{g} \pm 5\%$	
Body material	Al, (platform: steel)		L
Recommended amplifier/controller (codes explained p. 2-17)	H, E		

* For calibration information see p. 2-8. Resolution of PI piezo nanopositioners is not limited by friction or stiction. The value given is noise equivalent motion with E-503 amplifier.

** Dynamic Operating Current Coefficient in μA per Hz and μm .
Example: Sinusoidal scan of $30 \mu\text{m}$ at 10 Hz requires approximately 0.6 mA drive current.

P-62x.1 – Piezo Flexure Linear Slides

PIHera® Nanopositioning & Scanning Stages with Direct Metrology



PIHera® piezo nanotranslation stages with travel ranges from 50 µm to 1800 µm

- Record Travel Range for Piezo Flexure Stages: to 1800 µm
- Fast Response, Frictionless Motion, High Bandwidth
- Resolution <1 nm
- Frictionless Precision Flexure Guiding System
- PICMA® Long-Life, Ceramic Encapsulated Piezo Drives
- Direct Metrology with Capacitive Sensors for Highest Precision
- Up to 0.02 % Position Accuracy
- X, XY, Z, XYZ Versions
- Vacuum-Compatible Versions

P-620.1CD – P-629.1CD PIHera® systems are piezo-nanopositioning stages featuring travel ranges from 50 to 1800 µm. Despite the increased travel ranges, the units are extremely compact and provide sub-nanometer resolution. The long travel range is achieved with a newly designed, friction-free and extremely stiff flexure system, which also offers rapid response and excellent guiding accuracy (typically less than 5 µrad pitch/yaw over the full travel range).

Application Examples

- (Dynamic) interferometry
- Microscopy
- Nanopositioning
- Biotechnology
- Quality assurance
- Semiconductor technology

Superior Accuracy Through Direct-Motion Metrology with Capacitive Sensors

The capacitive-sensor-equipped versions provide motion linearity to 0.02 % with effective resolution in the sub-nanometer range. PI capacitive sensors are absolute-measuring, direct-metrology devices that boast

very high bandwidth and exhibit no periodic errors.

Unlike conventional sensors, capacitive sensors measure the actual distance between the fixed frame and the moving part of the stage. They detect errors contributed by all components in the drive train—from the actuator through the flexures to the platform. This results in higher motion linearity, long-term stability, phase fidelity, and—because external disturbances are seen by the sensor immediately—a stiffer, faster-responding servo-loop. See p. 2-4 ff. and p. 5-2 ff. for more information.

Nanometer Precision in Milliseconds

One of the advantages of PIHera® stages over motor-driven positioning stages is the rapid response to input changes and fast and precise settling behavior. The P-622.1CD, for example, can settle to an accuracy of 10 nm in only 30 msec (other PI stages provide even faster response)!

Single & Multi-Axis Versions

See page 2-42 and page 2-54 for Z and XY versions. XZ and XYZ combinations can be assembled without adapters.

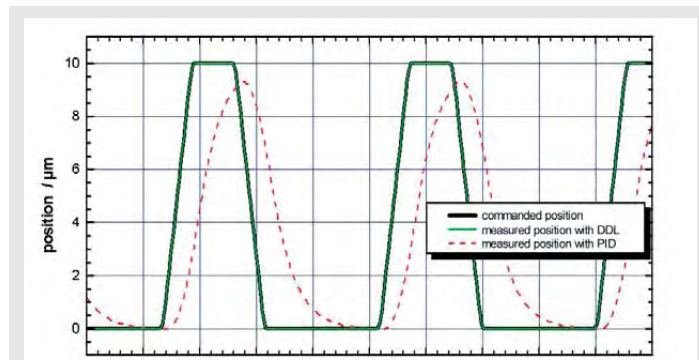

Rapid scanning motion of a P-621.1CD (commanded rise time 5 ms) with the E-710 controller and DDL option. Digital Dynamic Linearization virtually eliminates the tracking error (<20 nm) during the scan. The improvement over a classical PID controller is up to 3 orders of magnitude, and grows with the scanning frequency

Ordering Information

P-620.1CD * / P-620.1CL *
PIHera® Nanopositioning System, 50 µm, Capacitive Sensors

P-620.10L
PIHera® Nanopositioning System, 60 µm, Open-Loop, LEMO Conn.

P-621.1CD * / P-621.1CL *
PIHera® Nanopositioning System, 100 µm, Capacitive Sensors

P-621.10L
PIHera® Nanopositioning System, 120 µm, Open-Loop, LEMO Conn.

P-622.1CD * / P-622.1CL *
PIHera® Nanopositioning System, 250 µm, Capacitive Sensors

P-622.10L
PIHera® Nanopositioning System, 300 µm, Open-Loop, LEMO Conn.

P-625.1CD * / P-625.1CL *
PIHera® Nanopositioning System, 500 µm, Capacitive Sensors

P-625.10L
PIHera® Nanopositioning System, 600 µm, Open-Loop, LEMO Conn.

P-628.1CD * / P-628.1CL
PIHera® Nanopositioning System, 800 µm, Capacitive Sensors

P-628.10L
PIHera® Nanopositioning System, 950 µm, Open-Loop, LEMO Conn.

P-629.1CD * / P-629.1CL *
PIHera® Nanopositioning System, 1500 µm, Capacitive Sensors

P-629.10L
PIHera® Nanopositioning System, 1800 µm, Open-Loop, LEMO Conn.

* .1CD with Sub-D Connector
* .1CL with LEMO Connectors

Vacuum versions to 10⁻⁹ hPa are available as part numbers P-62x.1UD

Custom sizes & specifications available!

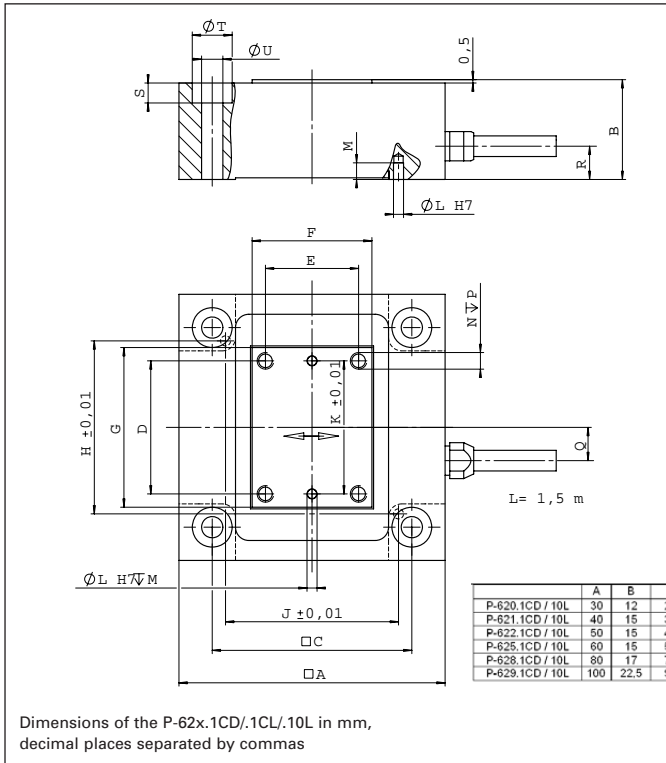

PIHera® XYZ combination

	A	B	C	D	E	F	G	H	J	K	ØL	M	N	P	Q	R	S	ØT	ØU
P-620.1CD / 10L	30	12	24	15	12	15	18	19	24	15	1.01	1.5	M2	4	4.5	6	2	4.4	2.2
P-621.1CD / 10L	40	15	30	20	14	18	24	26	26	20	1.51	2.5	M2.5	5	5	5	3	6	3.2
P-622.1CD / 10L	50	15	40	24	20	25	30	35	35	24	1.51	2.5	M2.5	5	5.5	5	3	6	3.2
P-625.1CD / 10L	60	15	50	40	27	32	44.5	46	46	40	1.51	2.5	M2.5	5	5.5	5	3	6	3.2
P-628.1CD / 10L	80	17	70	58	41	45	63	66	66	58	1.51	2.5	M2.5	5	5.5	5	3	6	3.2
P-629.1CD / 10L	100	22.5	90	60	40	60	84	82	82	60	2.01	3.5	M2.5	5	10	7.5	4	8	4.3

Technical Data

Models	P-620.1CD/ P-620.1CL	P-621.1CD/ P-621.1CL	P-622.1CD/ P-622.1CL	P-625.1CD/ P-625.1CL	P-628.1CD/ P-628.1CL	P-629.1CD P-629.1CL	P-62x.10L	Units
Active axes	X	X	X	X	X	X	X	
Open-loop travel -20 to 120 V	60	120	300	600	950	1800	see P-62x.1CD	µm
Closed-loop travel	50	100	250	500	800	1500	-	µm
Integrated feedback sensor	capacitive	capacitive	capacitive	capacitive	capacitive	capacitive	-	
* Closed-loop / open-loop resolution	0.2 / 0.1	0.4 / 0.2	0.7 / 0.4	1.4 / 0.5	1.8 / 0.5	2.5 / 2.0	- / see P-62x.1CD	nm
Closed-loop linearity (typ.)	0.02	0.02	0.02	0.03	0.03	0.03	-	%
Stiffness	0.42	0.35	0.15	0.10	-	0.13	see P-62x.1CD	N/µm
Push / pull force capacity (in X)	10/5	10/8	10/8	10/8	10/8	10/8	see P-62x.1CD	N
Max. Load	10	10	10	10	10	10	see P-62x.1CD	N
Lateral force limit	10	10	10	10	10	10	see P-62x.1CD	N
Tilt (θ_y, θ_z) (typ.)	3	3	3	6	6	30/10	see P-62x.1CD	µrad
Electrical capacitance	0.75	1.5	3.0	6.0	18.6	-	see P-62x.1CD	µF ±20 %
Dynamic operating current coefficient (DOCC)	1.9	1.9	1.5	1.5	-	-	see P-62x.1CD	µA/(Hz x µm)
Unloaded resonant frequency	1240	800	400	215	125	125	see P-62x.1CD	Hz ±20 %
Resonant frequency @ 20 g load	550	520	340	180	115	-	see P-62x.1CD	Hz ±20 %
Resonant frequency @ 120 g load	260	240	185	110	90	110	see P-62x.1CD	Hz ±20 %
Operating temperature range	-40 - 120	-40 - 120	-40 - 120	-40 - 120	-40 - 120	-40 - 120	-40 - 150	°C
Voltage Connection	D **	D **	D **	D **	D **	D **	VL	
Sensor Connection	D **	D **	D **	D **	D **	D **	-	
Weight (with cables)	108	158	195	238	375	720		g ±5 %
Body material	Al	Al	Al	Al	Al	Al	Al	
Recommended amplifier/controller (codes explained p. 2-17)	F, M, L, H	F, M, L, H	F, M, L, H	F, M, L, H	F, M, L, H	F, M, L, H	C, G	

* For calibration information see p. 2-8. Resolution of PI piezo nanopositioners is not limited by friction or stiction. The value given is noise equivalent motion with E-710 controller
 ** Version .1CL with Lemo connectors.

P-882 - P-888 Piezo Stack Linear Actuator

PICMA® High-Performance Monolithic Multilayer Piezo Actuators (LVPZT)

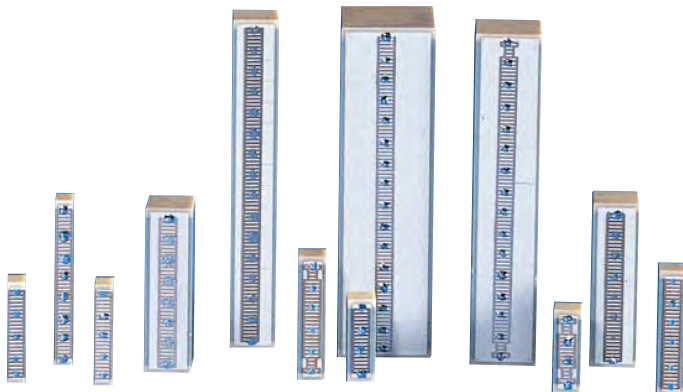

PICMA® piezo actuators are currently available with cross-sections of 2 x 3, 3 x 3, 5 x 5 and 10 x 10 mm.

- Award-Winning Technology
- Low Operating Voltage
- Superior Lifetime Even Under Extreme Conditions
- Very Large Operating-Temperature Range
- High Humidity Resistance
- Excellent Temperature Stability
- High Stiffness
- UHV Compatible to 10⁹ hPa
- Sub-Millisecond Response & Sub-Nanometer Resolution

Increased Lifetime and Higher Performance

PICMA® (PI Ceramic Monolithic Actuator) piezo actuators are characterized by their high performance and reliability, even in extremely harsh environ-

ments. They are superior to conventional multilayer actuators in industrial applications and high-endurance situations, where they show substantially longer lifetimes both in static and dynamic operation.

Application Examples

- Precision mechanics and mechanical engineering
- Nanopositioning / high-speed switching
- Active and adaptive optics
- Vibration cancellation
- Pneumatic & hydraulic valves
- Metrology / interferometry
- Life sciences, medicine and biology

New Production Process, Optimized PZT Ceramics

PICMA® piezo actuators are made from a ceramic material in which the piezoceramic properties such as stiffness, capacitance, displacement, temperature stability and lifetime are optimally combined. The actuators' monolithic design and special electrode structure was made possible by advances in production technology. This development is just one reflection of the more than 30 years experience

PI has with thousands of industrial PZT applications.

Increased Lifetime Through Humidity Resistance

The monolithic ceramic-encapsulated design provides better humidity protection than polymer-film insulation. Diffusion of water molecules into the insulation layer, is greatly reduced by the use of cofired, outer ceramic encapsulation.

High-Level Dynamic Performance—Very Wide Temperature Range

The high Curie temperature of 320 °C gives PICMA® actuators a usable temperature range extending up to 150 °C. This means that they can be operated in hotter environments, or they can be driven harder in dynamic operation. With conventional multilayer actuators, heat generation—which is proportional to operating frequency—either limits the operating frequency or duty cycle in dynamic operation, or makes ungainly cooling provisions necessary.

At the low end, operation down to a few Kelvin is possible (with reduction in performance specifications).



PICMA® actuator with optional wire leads and rounded top piece for decoupling lateral forces optional.

Optimum UHV Compatibility—No Outgassing

The lack of polymer insulation and the high Curie temperature make for optimal ultra-high-vacuum compatibility (no outgassing / high bakeout temperatures, up to 150 °C)

Ideal for Closed-Loop Operation

The ceramic surface of the actuators is extremely well suited for use with resistive or optical fiber strain gauge sensors. Such sensors can be easily applied to the actuator surface and exhibit significantly higher stability and linearity than with conventional polymer-insulated actuators.

Amplifiers, Drivers & Controllers

PI offers a wide range of control electronics for piezo actuators from low-power drivers to multichannel, closed-loop, digital controllers. Of course, PI also designs custom amplifiers and controllers.

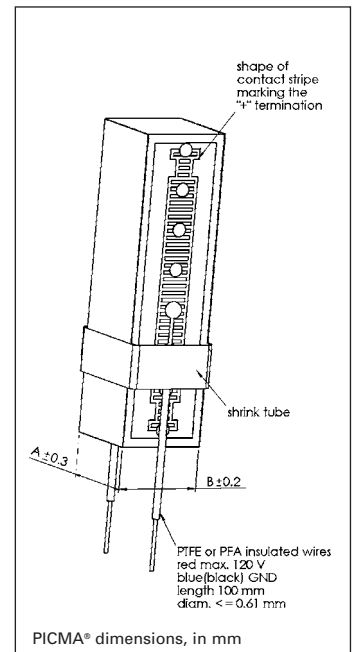

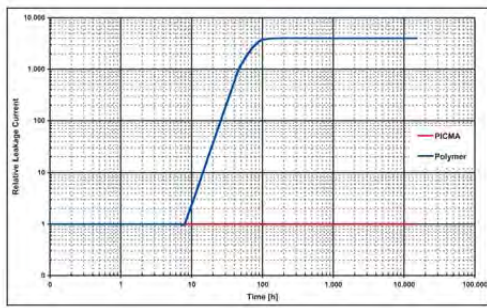

PICMA® piezo actuators (bottom curve) compared with conventional multilayer actuators with polymer insulation (top curve). PICMA® actuators are not affected by the high-humidity test conditions. Conventional piezo actuators exhibit increased leakage current after only a few hours. Leakage current is an indication of insulation quality and expected lifetime.

Test conditions: U = 100 V_{DC}; T = 25 °C; Relative Humidity = 70%

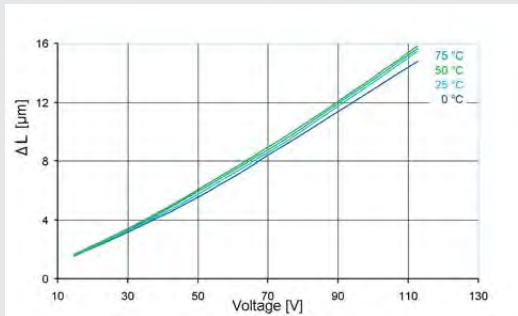

The displacement of PICMA® actuators exhibits very low temperature dependence. This, in combination with their low heat generation, makes PICMA® actuators optimal for dynamic operation.

(Operating frequency f = 200 Hz)**d**

Technical Data / Product Order Numbers

Order number*	Dimensions A x B x L [mm]	Nominal displacement [μm @ 100 V]	Max. displacement [μm @ 120 V]	Blocking force [N @ 120 V]	Stiffness [N/μm]	Electrical capacitance [μF] ±20%	Resonant frequency [kHz] ±20%
P-882.10	2 x 3 x 9	6.5 ±20%	8 ±20%	190	24	0.13	135
P-882.20	2 x 3 x 11	8.5 ±20%	10.5 ±20%	210	20	0.18	110
P-882.30	2 x 3 x 13.5	11 ±20%	13 ±20%	210	16	0.22	90
P-882.50	2 x 3 x 18	15 ±10%	18 ±10%	210	12	0.31	70
P-883.10	3 x 3 x 9	6.5 ±20%	8 ±20%	290	36	0.21	135
P-883.20	3 x 3 x 11	8.5 ±20%	10.5 ±20%	310	29	0.27	110
P-883.30	3 x 3 x 13.5	11 ±20%	13 ±20%	310	24	0.35	90
P-883.50	3 x 3 x 18	15 ±10%	18 ±10%	310	18	0.48	70
P-885.10	5 x 5 x 9	6.5 ±20%	8 ±20%	800	100	0.6	135
P-885.20	5 x 5 x 11	8.5 ±20%	10.5 ±20%	850	82	0.8	110
P-885.30	5 x 5 x 13.5	11 ±20%	13 ±20%	870	67	1.1	90
P-885.50	5 x 5 x 18	15 ±10%	18 ±10%	900	50	1.5	70
P-885.90	5 x 5 x 36	32 ±10%	38 ±10%	950	25	3.1	40
P-887.30	7 x 7 x 13.5	11 ±20%	13 ±20%	1700	130	2.2	90
P-887.50	7 x 7 x 18	15 ±10%	18 ±10%	1750	100	3.1	70
P-887.90	7 x 7 x 36	32 ±10%	38 ±10%	1850	50	6.4	40
P-888.30	10 x 10 x 13.5	11 ±20%	13 ±20%	3500	267	4.3	90
P-888.50	10 x 10 x 18	15 ±10%	18 ±10%	3600	200	6.0	70
P-888.90	10 x 10 x 36	32 ±10%	38 ±10%	3800	100	13.0	40

Recommended preload for dynamic operation
15 to 30 MPa

* For optional PTFE insulated wires, pigtail length 100 mm, change order number extension to .x1 (e.g. P-882.11).

Unloaded (longitudinal) resonant frequency measured at 1 V_{pp}; capacitance at 1 V_{pp}, 1 kHz.

Standard PZT ceramic type: PIC 52

Max. operating voltage: -20 to +120 V
Max. operating temperature: -40 to +150 °C

Standard Mechanical Interface: ceramic (top & bottom)
Standard Electrical Interface: solderable pads

Available Options: strain gauge sensors, special mechanical interfaces, etc.
Other specifications on request. Specifications subject to change without notice.

P-840/1 Preloaded Piezo Stack Actuator

Preloaded Open- & Closed-Loop Piezo Translators (LVPZT)



P-840, P-841 piezo translators (DIP switch for size comparison)

- Displacement to 90 μm
- Pushing Forces to 1000 N
- Preloaded for Pulling Forces to 50 N
- Sub-msec Response
- Sub-nm Resolution
- Options: Ball Tip, Vacuum Versions

P-840 and P-841 preloaded piezo translators are high-resolution linear actuators for static and dynamic applications. They provide sub-millisecond response and sub-nanometer resolution. The internal spring preload makes them ideal for dynamic applications.

High Accuracy in Closed-Loop Operation

The P-840 is specifically designed for open-loop operation. For highest accuracy, the P-841 closed-loop version includes integrated ultra-high-resolution strain gauge posi-

tion sensors and operate with PI servo-control electronics see page 4-19 ff. and page 4-31 ff. for details).

Design

These translators are equipped with highly reliable multilayer PZT ceramic stacks protected by a non-magnetic stainless steel case with internal spring preload. The standard translator tip and base have tapped holes. Select the P-840.95 ball tip option to help decouple off-axis or torque loads from the translator.

Mounting

For push/pull forces up to 5 N, the translator can be mounted by clamping around the case. For larger forces, the translator must be mounted by the base. For positioning of magnetic parts the P-176.20 magnetic adapter can be screwed into the translator tip.

For more mounting guidelines see page 1-48.

Ordering Information

- P-841.10**
Closed-Loop LVPZT Translator, 15 μm
- P-841.20**
Closed-Loop LVPZT Translator, 30 μm
- P-841.30**
Closed-Loop LVPZT Translator, 45 μm
- P-841.40**
Closed-Loop LVPZT Translator, 60 μm
- P-841.60**
Closed-Loop LVPZT Translator, 90 μm
- P-840.10**
Open-Loop LVPZT Translator, 15 μm
- P-840.20**
Open-Loop LVPZT Translator, 30 μm
- P-840.30**
Open-Loop LVPZT Translator, 45 μm
- P-840.40**
Open-Loop LVPZT Translator, 60 μm
- P-840.60**
Open-Loop LVPZT Translator, 90 μm

Ask about custom designs! **dd**

Technical Data

Models	Closed-Loop				
	P-841.10	P-841.20	P-841.30	P-841.40	P-841.60
Open-loop travel @ 0 to 100 V	15	30	45	60	90
Closed-loop travel	15	30	45	60	90
* Integrated feedback sensor	SGS	SGS	SGS	SGS	SGS
** Closed-loop / open-loop resolution	0.3 / 0.15	0.6 / 0.3	0.9 / 0.45	1.2 / 0.6	1.8 / 0.9
*** Static large-signal stiffness	57	27	19	15	10
Push/pull force capacity	1000 / 50	1000 / 50	1000 / 50	1000 / 50	1000 / 50
Torque limit (at tip)	0.35	0.35	0.35	0.35	0.35
Electrical capacitance	1.5	3.0	4.5	6.0	9.0
Dynamic operating current coefficient (DOCC)	12.5	12.5	12.5	12.5	12.5
Unloaded resonant frequency (f ₀)	18	14	10	8.5	6
Standard operating temperature range	-20 to +80	-20 to +80	-20 to +80	-20 to +80	-20 to +80
Voltage connection	VL	VL	VL	VL	VL
Sensor connection	L	L	L	L	L
Weight without cables	20	28	46	54	62
Material case / end pieces	N-S	N-S	N-S	N-S	N-S
Length L	32	50	68	86	122
Recommended amplifier/controller (codes explained p. 1-3)	C, D ,G , H	C, D ,G , H	C, D ,G , H	C, D ,G , H	C, D ,G , H

Application Examples

- Static and dynamic positioning
- Disk drive testing
- Smart structures
- Adaptive mechanics
- Vibration cancellation
- Switching
- Laser tuning
- Patch clamping

For more examples see page 1-5

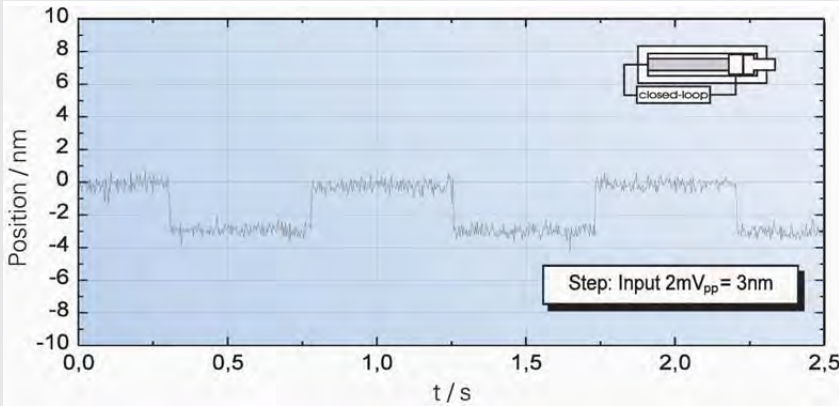

Response of a P-841.10 to a 3 nm peak-to-peak square wave control input signal, measured with servo-control bandwidth set to 240 Hz and 2 msec settling time. Note the crisp response to the square wave control signal.

Factory Installed Options

P-703.20

High-Vacuum Option
(see p. 1-44)

P-840.95

Ball Tip (see page 1-44)

Accessories

P-176.20

Magnetic adapter with M3 threaded stud, see page 1-45.
Extension cables & connectors: see page 6-55 in the "Piezo Drivers & Nanopositioning Controllers" section.

Notes

See the "Piezo Drivers & Nanopositioning Controllers" section for our comprehensive line of low-noise modular and OEM control electronics for computer and manual control.

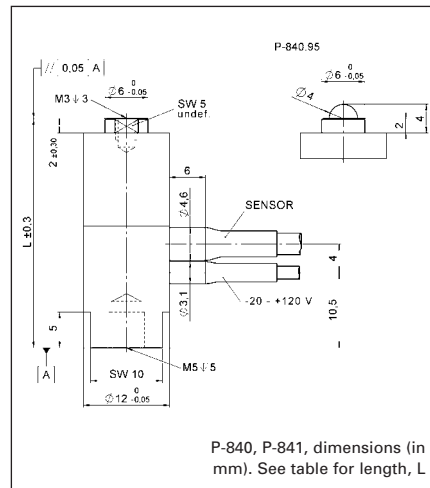

P-840, P-841, dimensions (in mm). See table for length, L

Open-Loop

P-840.10	P-840.20	P-840.30	P-840.40	P-840.60	Units	Notes see page 1-46
15	30	45	60	90	$\mu\text{m} \pm 20\%$	A2
-	-	-	-	-	μm	A5
-	-	-	-	-		B
- / 0.15	- / 0.3	- / 0.45	- / 0.6	- / 0.9	nm	C1
57	27	19	15	10	$\text{N}/\mu\text{m} \pm 20\%$	D1
1000 / 50	1000 / 50	1000 / 50	1000 / 50	1000 / 50	N	D3
0.35	0.35	0.35	0.35	0.35	Nm	D6
1.5	3.0	4.5	6.0	9.0	$\mu\text{F} \pm 20\%$	F1
12.5	12.5	12.5	12.5	12.5	$\mu\text{A}/(\text{Hz} \times \mu\text{m})$	F2
18	14	10	8.5	6	$\text{kHz} \pm 20\%$	G2
-20 to +80	-20 to +80	-20 to +80	-20 to +80	-20 to +80	$^{\circ}\text{C}$	H2
VL	VL	VL	VL	VL		J1
-	-	-	-	-		J2
20	28	46	54	62	$\text{g} \pm 5\%$	K
N-S	N-S	N-S	N-S	N-S		L
32	50	68	86	122	$\text{mm} \pm 0.3$	
C,G	C,G	C,G	C,G	C,G		

* Closed-loop models can attain linearity up to 0.15% and are shipped with performance reports.
** Resolution of piezo actuators is not limited by friction or stiction.
Noise equivalent motion with E-503 amplifier;
*** Dynamic small-signal stiffness ~30% higher.

P-842 Preloaded Piezo Stack Linear Actuator

Preloaded Piezo Actuators (LVPZT) with Sensor Option

P-844 piezo actuators (battery for size comparison)



- Travel Range to 90 μm
- Pushing Forces to 3000 N
- Preloaded for Pulling Forces to 700 N
- Sub-ms Response
- Sub-nm Resolution
- Options: Vacuum Versions, Water-Resistant Case

P-842, P-843, P-844 and P-845 series piezo translators are high-resolution linear actuators for static and dynamic applications. They provide sub-millisecond response and sub-nanometer resolution.

Design

These actuators consist of a friction-free, preloaded, monolithic multilayer piezoceramic stack protected by a stainless steel case.

The high preload gives these actuators outstanding properties for dynamic applications (e.g. precision machining, active damping, etc.) and push-pull applications.

Mounting

Mounting is at the foot, although with push/pull forces of less than 100 N, the actuator

can be held by clamping the case. The P-176.50 / P-176.60 flexible tips can be installed to decouple the ceramic from bending forces (see page 1-45). For more mounting guidelines, see page 1-48.

High Accuracy in Closed-Loop Operation

The P-842 and P-844 are designed for open-loop positioning tasks. The P-843 and P-845 versions are equipped with integrated high-resolution SGS position sensors and offer high-accuracy, closed-loop operation (for more information, see the "Tutorial: Piezo-electrics in Positioning," Section 4).

Options:

P-703.20

High-vacuum option, p. 1-44.

Application Examples

- Static and dynamic precision positioning
- Disk drive testing equipment
- Optics
- Metrology / interferometry
- Active structures (Adaptronics)
- Precision engineering / micromechanisms
- Adaptive mechanics
- Active vibration control
- Switching applications
- Laser tuning

For more examples, see page 1-5

Technical Data and Product Order Numbers

Order number	Travel range (open-loop) for 0 to 100 V [μm] $\pm 20\%$	Travel range (closed-loop) [μm]	Integrated position sensor*	Resolution closed-loop / open-loop [nm]**	Static large-signal stiffness [N/ μm] $\pm 20\%$ ***
P-842.10	15	-	-	- / 0.15	57
P-842.20	30	-	-	- / 0.3	27
P-842.30	45	-	-	- / 0.45	19
P-842.40	60	-	-	- / 0.6	15
P-842.60	90	-	-	- / 0.9	10
P-843.10	15	15	SGS	0.3 / 0.15	57
P-843.20	30	30	SGS	0.6 / 0.3	27
P-843.30	45	45	SGS	0.9 / 0.45	19
P-843.40	60	60	SGS	1.2 / 0.6	15
P-843.60	90	90	SGS	1.8 / 0.9	10
P-844.10	15	-	-	- / 0.15	225
P-844.20	30	-	-	- / 0.3	107
P-844.30	45	-	-	- / 0.45	75
P-844.40	60	-	-	- / 0.6	57
P-844.60	90	-	-	- / 0.9	38
P-845.10	15	15	SGS	0.3 / 0.15	225
P-845.20	30	30	SGS	0.6 / 0.3	107
P-845.30	45	45	SGS	0.9 / 0.45	75
P-845.40	60	60	SGS	1.2 / 0.6	57
P-845.60	90	90	SGS	1.8 / 0.9	38
Notes see page 1-46	A2	A5	B	C1	D1

Accessories

P-176.50

Flexible tip for P-842 / P-843, see p. 1-45

P-176.60

Flexible tip for P-844 / P-845, see p. 1-45
 Extension cables with connectors: see pp. 6-55 ff.

Note

High-resolution amplifiers and servo-control electronics, both digital and analog, are described in the "Piezo Drivers & Nanopositioning Controllers" section, page 6-8 ff.

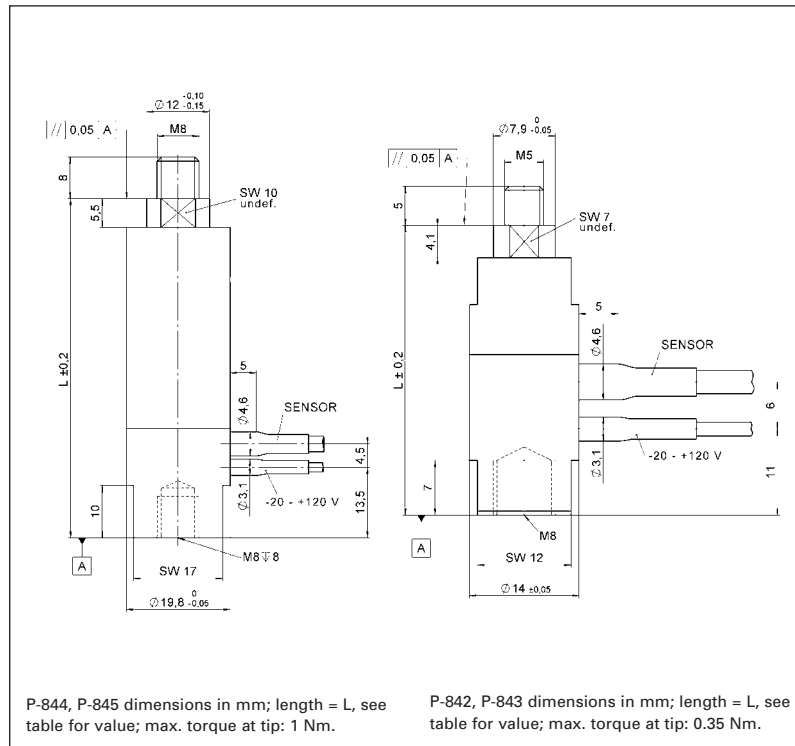

Push/pull force capacity [N]	Electrical capacitance [μ F] $\pm 20\%$	Dynamic operating current coefficient [μ A / (Hz x μ m)]	Resonant frequency (unloaded) [kHz] $\pm 20\%$	Weight without cable [g] $\pm 5\%$	Length L [mm]	Recommended amplifier/controller (codes explained p. 1-3)
800 / 300	1.5	12.5	18	31	37	C, G
800 / 300	3.0	12.5	14	42	55	C, G
800 / 300	4.5	12.5	10	53	73	C, G
800 / 300	6.0	12.5	8.5	64	91	C, G
800 / 300	9.0	12.5	6	86	127	C, G
800 / 300	1.5	12.5	18	31	37	D, H
800 / 300	3.0	12.5	14	42	55	D, H
800 / 300	4.5	12.5	10	53	73	D, H
800 / 300	6.0	12.5	8.5	64	91	D, H
800 / 300	9.0	12.5	6	86	127	D, H
3000 / 700	6.0	50	16	84	47	C, G
3000 / 700	12.0	50	12	108	65	C, G
3000 / 700	18.0	50	9	132	83	C, G
3000 / 700	24.0	50	7.5	156	101	C, G
3000 / 700	36.0	50	5.5	204	137	C, G
3000 / 700	6.0	50	16	84	47	D, H
3000 / 700	12.0	50	12	108	65	D, H
3000 / 700	18.0	50	9	132	83	D, H
3000 / 700	24.0	50	7.5	156	101	D, H
3000 / 700	36.0	50	5.5	204	137	D, H
D3	F1	F2	G2	K		

Voltage connection: LEMO FFA.00.250; 1 m coaxial cable, RG 178, teflon insulation.
 Sensor connection: LEMO FFA.0S.304; 1 m coaxial cable with PUR insulation.
 Temperature range: -40 to 80 °C.
 Case / end pieces: non-magnetic steel

* SGS versions can attain closed-loop linearity up to 0.15% and are shipped with performance reports.
 ** The resolution of piezo actuators is not limited by stiction or friction. Value given is noise equivalent motion with E-503 amplifier.
 *** Dynamic smallsignal stiffness is ~30% higher.

P-212 · P-216 Piezo Stack Linear Actuator

Preloaded Open- & Closed-Loop PICA™ Power Piezo Actuators (HVPZT) with Sensor Option



From left:
P-212.1S and .8S, P-216.9S,
.4S and .1S piezo actuators
(CD for size comparison)

- Travel Range to 180 µm
- Pushing Forces to 4500 N
- Pulling Forces to 500 N
- Sub-millisecond Response
- Sub-nanometer Resolution
- Options: Vacuum, High- and Low-Temperature

The P-212 and P-216 series are high-resolution linear piezo actuators (translators) for static and dynamic applications. They provide sub-millisecond response and sub-nanometer resolution.

Application Examples

- Optics
- Metrology / Interferometry
- Adaptronics
- Precision engineering / micromechanics
- Adaptive mechanics
- Active vibration damping
- Switches
- Laser tuning
- Force generation / materials testing
- Nanotechnology

These actuators have the friction-free, preloaded PICA™ Power actuators inside. The preload makes them ideal for dynamic applications like precision machining or active damping.

High Displacement with Ultra-High Reliability

PICA™ Power actuators are optimized for high-temperature working conditions and high-duty-cycle dynamic applications.

All PICA™ piezo ceramics are specifically designed for high-duty-cycle applications. With PI's extensive applications knowledge, gained over several decades, performance does not come at the price of reliability. All materials used are specifically matched for robustness and lifetime. Endurance tests on PICA™ actua-

Ordering Information

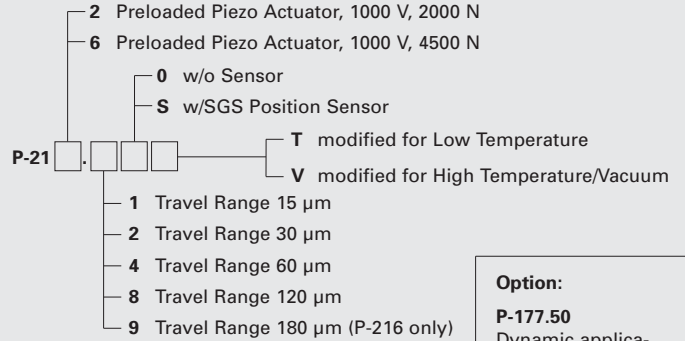

Please read "Options and Accessories", page 1-44 ff, for further information.
Extensions cables, adapters & connectors: see in "Accessories" in the "Piezo Drivers & Nanopositioning Controllers" section.

Option:
P-177.50
Dynamic applications (with E-481): temperature sensor and protective air for PICA™ HVPZT

tors prove consistent performance, even after billions (1,000,000,000) of cycles.

guide in the „Piezo Drivers & Nanopositioning Controllers“ section page 6-2 ff.

Mechanical Mounting

Mounting is at the foot, with push/pull forces of less than 5 N, the actuator can be held by clamping the case. The optional ball tip is intended to decouple torque and off-center forces from the translator. Read details in Mounting and Handling Guidelines page 1-48.

High Flexibility with PI Amplifiers, Drivers & Controllers

PI offers a wide range of control electronics for piezo actuators from low-power drivers to the high-performance amplifier / controller E-481.

For closed-loop operation PI offers a wide variety of analog and digital controllers. The E-500 modular system can be easily upgraded from an amplifier to a servo controller, including different interface / display modules.

Notes

High-resolution amplifiers and servo-control electronics, both digital and analog, see selection

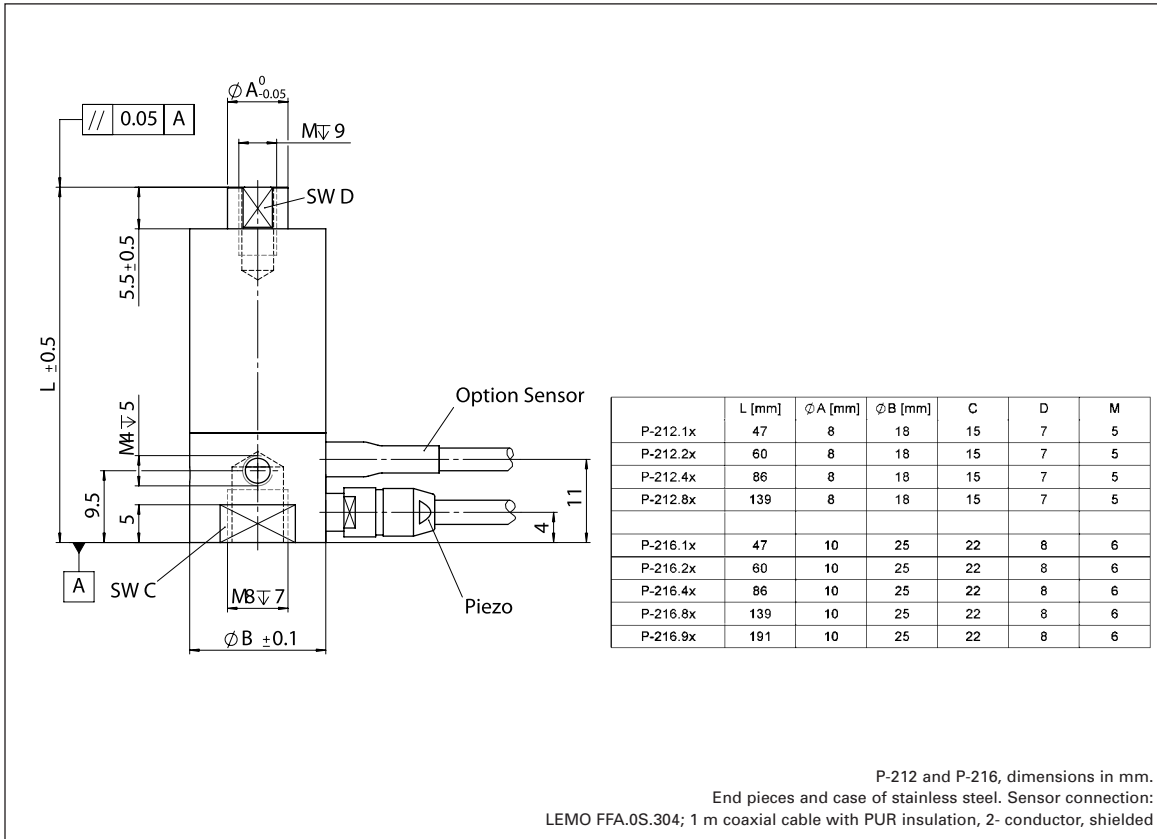

Technical Data

	P-212.10	P-212.20	P-212.40	P-212.80	P-216.10	P-216.20	P-216.40	P-216.80	P-216.90	Einh.	Toleranz
Operating voltage	0 to 1000	0 to 1000	0 to 1000	0 to 1000	0 to 1000	0 to 1000	0 to 1000	0 to 1000	0 to 1000	V	
Motion and positioning											
Closed-loop travel	15	30	60	120	15	30	60	120	180	μm	
Closed-loop resolution**	0.3	0.6	1.2	2.4	0.3	0.6	1.2	2.4	3.6	nm	typ.
Open-open resolution**	0.15	0.3	0.6	1.2	0.15	0.3	0.6	1.2	1.8	nm	typ.
Linearity*	0.2	0.2	0.2	0.2	0.2	0.2	0.2	0.2	0.2	%	typ.
Mechanical properties											
Static large-signal stiffness***	90	60	34	18	210	140	80	50	32	N/μm	±20%
Unloaded resonant frequency	17	12	7	4.5	17	12	7	4.5	3	kHz	±20%
Push/pull force capacity	2000/300	2000/300	2000/300	2000/300	4500/500	4500/500	4500/500	4500/500	4500/500	N	Max.
Shear force limit	15	10	10	10	60	36	23	23	23	N	
Torque limit (on tip)	0.5	0.5	0.5	0.5	1	1	1	1	1	Nm	
Drive properties											
El. capacitance	47	90	180	370	130	250	500	1000	1500	nF	±20%
Dynamic operating current coefficient	5	5	5	5	13	13	13	13	13	μA/(Hz x μm)	±20%
Miscellaneous											
Mass (with cable)	110	120	150	210	170	200	250	370	480	g	±5%

* Requires SGS sensor. SGS versions are shipped with performance reports

** Measured with an Interferometer. The resolution of piezo actuators is not limited by stiction or friction

*** Dynamic small-signal stiffness is ~50% higher

Piezo ceramic type: PICA™ Power

Operating temperature range: -40 to +80 °C

Recommended controller/driver: B, I, J, see codes explanation page 6-11

For maximum lifetime, voltages in excess of 750 V should be applied only for short durations

See Notes (Technical Data) for further information page 2-84 ff

P-225 · P-235 Piezo Stack Linear Actuator

Preloaded PICA™ Power High-Load Piezo Actuators (HVPZT) with Sensor Options



High-load piezo actuators P-235.1S, .4S and .9S, P-225.8S and .1S (from left) with CD for size comparison

- **Extremely High Stiffness**
- **Pushing Forces to 30,000 N**
- **Pulling Forces to 3500 N**
- **Travel Ranges to 180 µm**
- **Options: Versions for Vacuum, High- and Low-Temperatures and with Water-Resistant Case**

P-225 and P-235 are preloaded, high-load piezo actuators (translators) for static and dynamic applications. They provide sub-millisecond response and sub-nanometer resolution.

Application Examples

- Precision engineering / micromechanics
- Adaptive mechanics
- Active vibration damping
- Adaptronics
- Static and dynamic precision positioning
- Force generation / materials testing

These ultra-high-force linear actuators consist of PICA™ Power piezoelectric ceramic-stacks encapsulated in a stainless steel case with stainless steel end pieces and a frictionless internal spring preload. The high load capacity and preload makes them ideal for machining applications and active vibration cancellation.

High Displacement with Ultra-High Reliability

PICA™ Power actuators are optimized for high-temperature working conditions and high-duty-cycle dynamic applications.

All PICA™ piezo ceramics are specifically designed for high-duty-cycle applications. With PI's extensive applications knowledge, gained over sever-

Ordering Information

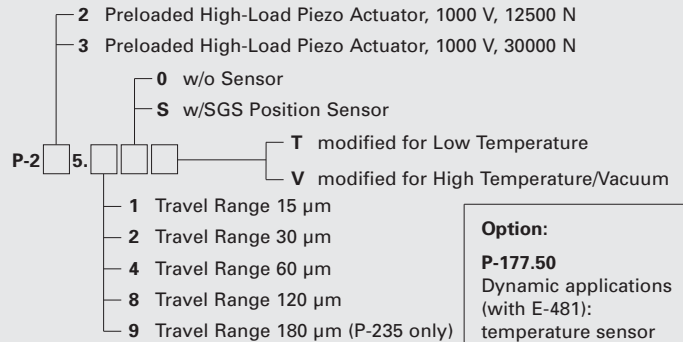

Please read "Options and Accessories", page 1-44 ff, for further information.

Extensions cables, adapters & connectors: see in "Accessories" in the "Piezo Drivers & Nanopositioning Controllers" section.

Option:

P-177.50

Dynamic applications (with E-481): temperature sensor and protective air for PICA™ HVPZT

P-706.00

Water-resistant case

al decades, performance does not come at the price of reliability. All materials used are specifically matched for robustness and lifetime. Endurance tests on PICA™ actuators prove consistent performance, even after billions (1,000,000,000) of cycles.

Open- and Closed-Loop Models for Optimum Dynamics and Linearity

The standard models are ideal for open loop positioning applications. In this mode the actuator displacement is roughly proportional to the applied voltage.

Open-loop operation is ideal for applications where the fastest response and the highest bandwidth are essential. Here, commanding and reading the target position in absolute values is either not important or carried out by an external feedback loop.

For highest positioning accuracy and repeatability, select the factory installed closed-loop option with integrated ultra-high-resolution strain gauge position sensors and operate with PI servo-control electronics. For more information, read

the "Tutorial: Piezoelectrics in Nanopositioning".

High Flexibility with PI Amplifiers, Drivers & Controllers

PI offers a wide range of control electronics for piezo actuators from economical, low-power piezo drivers to the E-481 high-performance amplifier / controller providing 2000 W of dynamic power.

For closed-loop operation a wide variety of analog and digital controllers is available. The E-500 modular system can be easily upgraded from an amplifier to a servo controller, including different interface / display modules.

Read details in Mounting and Handling Guidelines page 1-48.

Notes

High-resolution amplifiers and servo-control electronics, both digital and analog, see selection guide in the "Piezo Drivers & Nanopositioning Controllers" section page 6-2 ff.

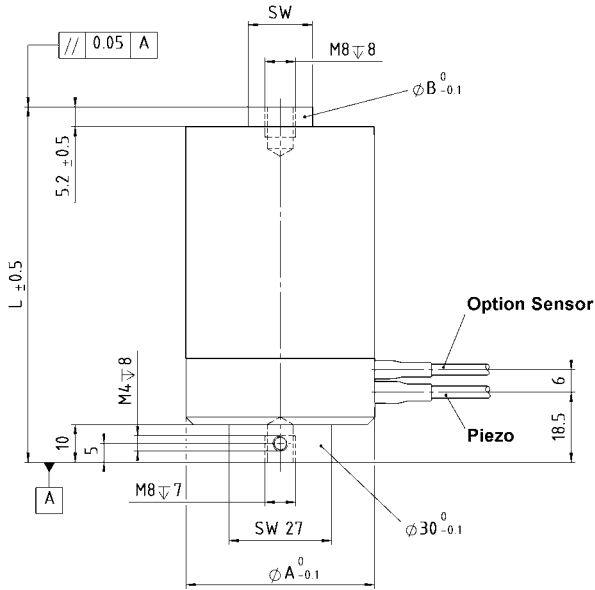

	L [mm]	∅ A [mm]	∅ B [mm]	SW
P-225.1x	55	39.8	16	13
P-225.2x	68	39.8	16	13
P-225.4x	94	39.8	16	13
P-225.8x	147	39.8	16	13
P-235.1x	55	49.8	20	17
P-235.2x	68	49.8	20	17
P-235.4x	94	49.8	20	17
P-235.8x	147	49.8	20	17
P-235.9x	199	49.8	20	17

P-225 and P-235, dimensions in mm. End pieces and case of stainless steel.
 Sensor connection: LEMO FFA.0S.304; 1 m coaxial cable with PUR insulation.
 Voltage connection: LEMO FGG.0B.701.CJA.1173, 1 m cable with PUR insulation,
 2-conductor, shielded

Technische Daten

	P-225.10	P-225.20	P-225.40	P-225.80	P-235.10	P-235.20	P-235.40	P-235.80	P-235.90	Unit	Tolerance
Operating voltage	0 to 1000	0 to 1000	0 to 1000	0 to 1000	0 to 1000	0 to 1000	0 to 1000	0 to 1000	0 to 1000	V	
Motion and positioning											
Closed-loop travel	15	30	60	120	15	30	60	120	180	µm	
Open-loop resolution**	0,3	0,6	1,2	2,4	0,3	0,6	1,2	2,4	3,6	nm	typ.
Closed-loop resolution****	0,15	0,3	0,6	1,2	0,15	0,3	0,6	1,2	1,8	nm	typ.
Linearity	0,2	0,2	0,2	0,2	0,2	0,2	0,2	0,2	0,2	%	typ.
Mechanical properties											
Static large-signal stiffness***	480	330	200	110	860	600	380	210	150	N/µm	±20
Unloaded resonant frequency	14	10	7	4	14	10	7	3,9	2,8	kHz	±20 %
Push/pull force capacity	12500 / 2000	12500 / 2000	12500 / 2000	12500 / 2000	30000 / 3500	30000 / 3500	30000 / 3500	30000 / 3500	30000 / 3500	N	Max.
Shear force limit	255	152	84	73	707	420	232	147	147	N	
Torque limit (on tip)	1,5	1,5	1,5	1,5	2	2	2	2	2	Nm	
Drive properties											
El. capacitance	320	630	1300	2600	550	1100	2400	5100	7800	nF	±20 %
Dynamic operating current coefficient	33	33	33	33	65	65	65	65	65	µA/(Hz x µm)	±20 %
Miscellaneous											
Mass (with cable)	410	470	610	900	580	690	940	1400	1900	g	±5 %

* Requires SGS sensor. SGS versions are shipped with performance reports
 ** Measured with an interferometer. The resolution of piezo actuators is not limited by stiction or friction
 *** Dynamic small-signal stiffness is ~50 % higher
 Piezo ceramic type: PICA™ Power
 Operating temperature range: -40 to +80 °C
 Recommended controller/driver: B, I, J, see page 6-11
 For maximum lifetime, voltages in excess of 750 V should be applied only for short durations
 See Notes (Technical Data) for further information see page 2-84 ff

M-228 · M-229 Stepper Linear Actuator Series

High-Load, Compact and Highly Cost-Efficient, with Limit Switches

M-228 and M-229 series linear actuators are driven by powerful direct-drive stepper motors, or are equipped with more compact, gearhead stepper motors: M-229.26S, M-228.11S, M-229.25S, M-228.10S (from left)



- **Highly Cost-Efficient, Compact Design**
- **10 and 25 mm Travel Range**
- **High Load Capacity to 80 N**
- **Gearhead Version: 46 nm Resolution (with C-663 Controller)**
- **Direct Drive: Max. Velocity 5 mm/s**
- **Non-Rotating Tip**
- **Non-Contact Limit and Reference Switches**

M-228 and M-229 series linear actuators provide a travel range of 10, resp. 25 mm, and are equipped with high-resolution stepper motors. The stepper mikes can push or pull loads up to 80 N, and provide speeds up to 5 mm/s. Models featuring gearhead/stepper motor combinations offer the same stroke in a more compact package.

Cost-Effective Design, Valuable Features

The cost-effective design offers many useful features such as a non-rotating tip, limit and reference switches and a mechanical position display.

A spherical tip and a 3 m extension cable are included in the delivery. The more compact gearhead versions include an additional flat tip.

Non-Rotating Tip

Compared to conventional rotating-tip micrometer drives, the non-rotating tip design offers several advantages:

- Elimination of torque-induced positioning errors
- Elimination of sinusoidal motion errors
- Elimination of wear at the contact point

- **Elimination of tip-angle-dependent wobble**

Limit and Reference Switches

For the protection of your equipment, non-contact Hall-effect limit and reference switches are installed. The direction-sensing reference switch supports advanced automation applications with high precision.

Low Cost of Ownership

The combination of these actuators with the networkable C-663 Mercury Step controller (s. p. 4-112) offers high performance for a very competitive price in both single and multi-axis configurations.

Ordering Information

M-228.10S
Stepper-Mike Linear Actuator, 10 mm, Stepper Motor, Gearhead, Limit Switches

M-228.11S
Stepper-Mike Linear Actuator, 10 mm, Stepper Motor, Direct Drive, Limit Switches

M-229.25S
Stepper-Mike Linear Actuator, 25 mm, Stepper Motor, Gearhead, Limit Switches

M-229.26S
Stepper-Mike Linear Actuator, 25 mm, Stepper Motor, Direct Drive, Limit Switches

Ask about custom designs!

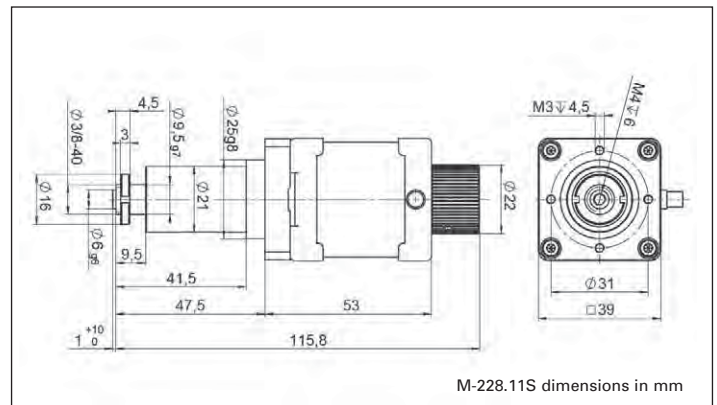

M-229 high-load stepper mike with gearhead, C-663 Mercury stepper motor controller (rear)

Application Examples

- Quality assurance testing
- Testing equipment
- Alignment of secondary mirrors
- Automation
- Metrology
- Precision machining

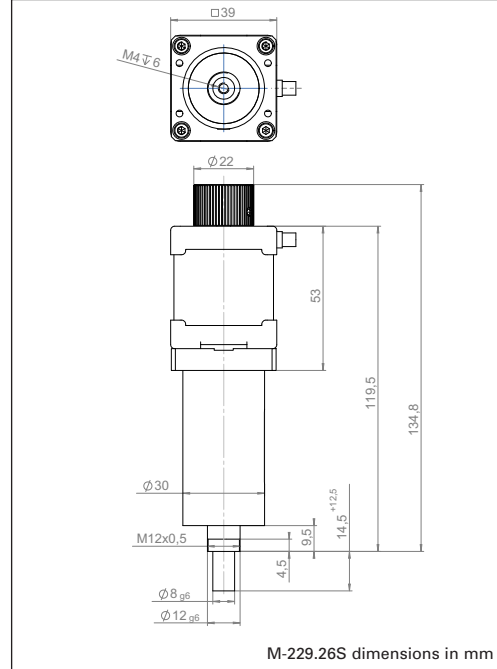
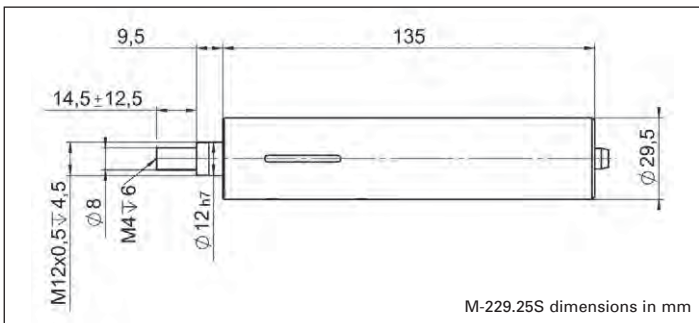
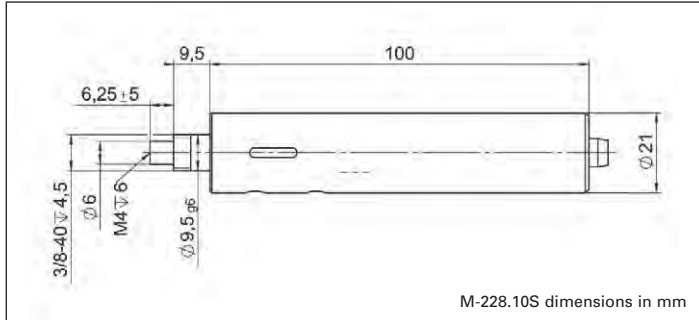

Technical Data

Model	M-228.10S	M-228.11S	M-229.25S	M-229.26S	Units
Active axes	X	X	X	X	
Motion and positioning					
Displacement	10	10	25	25	mm
Design resolution*	0.046	0.078	0.046	0.078	µm
Min. incremental motion*	1	1	1	1	µm
Backlash**	5	10	10	10	µm
Unidirectional repeatability	±2	±2	±2	±2	µm
Max. velocity*	1.5	5	1.5	5	mm / s
Reference switch repeatability	1	1	1	1	µm
Mechanical properties					
Drive screw	Leadscrew	Leadscrew	Leadscrew	Leadscrew	
Thread pitch	0.5	0.5	0.5	0.5	mm / rev.
Gear ratio	28.44444:1	–	28.44444:1	–	
Motor resolution*	384	6400	384	6400	steps / rev.
Max. push/pull force	20	50	50	80	N
Drive properties					
Motor type	2-phase stepper motor	2-phase stepper motor	2-phase stepper motor	2-phase stepper motor	
Operating voltage	24***	24*	24**	24*	V
Reference and limit switches	Hall-effect	Hall-effect	Hall-effect	Hall-effect	
Miscellaneous					
Operating temperature range	-20 to +65	-20 to +65	-20 to +65	-20 to +65	°C
Material	Al-(anodized), steel, brass	Al-(anodized), steel, brass	Al-(anodized), steel, brass	Al-(anodized), steel, brass	
Mass	0.23	0.36	0.4	0.61	kg
Cable length	0.5	0.6	0.5	0.6	m
Connector	15-pin sub-D connector	15-pin sub-D connector	15-pin sub-D connector	15-pin sub-D connector	
Recommended controller	C-663 single-axis	C-663 single-axis	C-663 single-axis	C-663 single-axis	

Please avoid lateral forces at the tip.

* with C-663 stepper motor controller
 ** with preload
 *** max. 0.25 A / phase; 24 full steps / rev.
 * max. 0.85 A / phase; 400 full steps / rev.
 ** max. 1 A / phase; 24 full steps / rev.

M-227 Servo Motor Actuators

High-Resolution DC-Mike Actuators

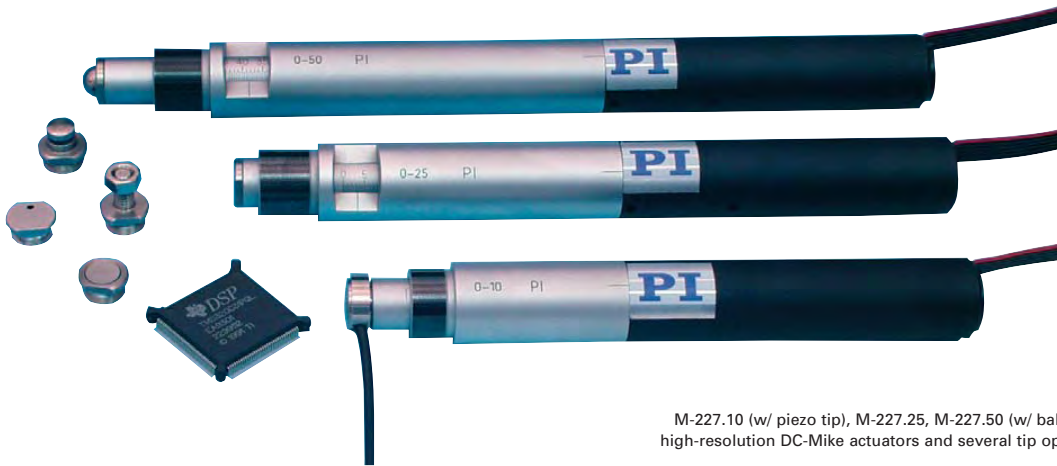

M-227.10 (w/ piezo tip), M-227.25, M-227.50 (w/ ball tip), high-resolution DC-Mike actuators and several tip options

- 10, 25 & 50 mm Travel Ranges
- 0.05 μm Minimum Incremental Motion
- Non-Rotating Tip
- Closed-Loop DC Motor
- Compatible with Leading Industrial Motion Controllers
- Sub-nm Resolution with Optional PZT Drive
- >5,000 Hours MTBF

M-227 are ultra-high-resolution linear actuators providing linear motion up to 50 mm with sub-micron resolution in a compact package. They consist of a micrometer with non-rotating tip, driven by a closed-loop DC-motor/gearhead combination with motor-shaft-mounted high-resolution encoder (2048 counts/rev.).

Non-Rotating Tip

Compared to conventional rotating-tip micrometer drives the non-rotating-tip design offers several advantages; it eliminates:

- Torque-induced stage platform tilt
- Sinusoidal motion errors
- Wear at the contact point
- Tip-angle-dependent wobble

M-227 actuators provide a cost-effective solution for industrial and OEM environments. Based on the successful M-222/M-226 series which they replace, M-227 DC Mikes offer both improved specs and reduced costs. The combination of an extremely low stiction/friction construction and high-resolution encoder allows for a minimum incremental motion of 50 nanometers at speeds up to 1 mm/sec.

Integrated Line Drivers

Each actuator includes an integrated 0.1 m cable with 15-pin sub-D connector and a 3 m extension cable. The connector features integrated line drivers for cable lengths up to 10 meters between actuator and controller.

Ordering Information

- M-227.10**
DC-Mike Actuator, 10 mm
- M-227.25**
DC-Mike Actuator, 25 mm
- M-227.50**
DC-Mike Actuator, 50 mm
- M-219.10**
Ball Tip
- M-250.20**
Piezo Translator

Ask about custom designs!

High-Resolution Piezo Option

All models come with standard flat tips. A variety of other tips are also available, such as a piezoelectric tip featuring 20 μm travel with sub-nanometer resolution for dynamic scanning and tracking (see page 7-85).

For mounting, the DC-Mikes are clamped around the 19 mm diameter section. High forces around the 16 mm diameter section must be avoided, as must be lateral forces on the tip.

Stepper-motor-driven versions of the M-227 are available on request. For higher loads and integrated limit switches refer to the M-230 and M-235 (see pages 7-78 and 7-82).

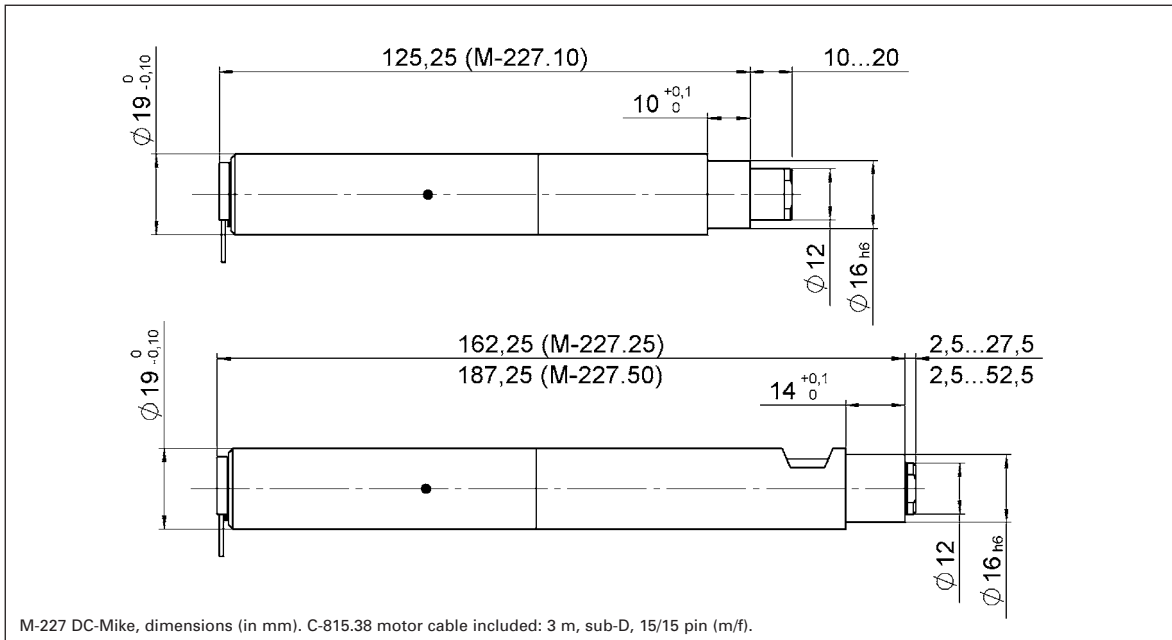
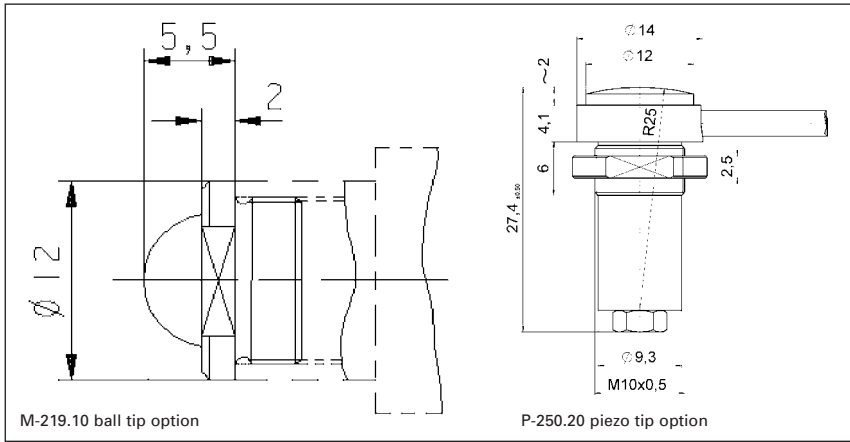

Technical Data

Models	M-227.10	M-227.25	M-227.50	Units	Notes see page 7-106
Travel range	10	25	50	mm	
Design resolution	0.0035	0.0035	0.0035	μm	A3
Min. incremental motion	0.05	0.05	0.05	μm	A4
Unidirectional repeatability	0.1	0.1	0.1	μm	
Backlash	2	2	2	μm	
Max. velocity	1	1	1	mm/s	
Max. push/pull force*	40	40	40	N	
Max. lateral force	0.1	0.1	0.1	N (at tip)	
Encoder resolution	2048	2048	2048	counts/rev.	
Drivescrew pitch	0.5	0.5	0.5	mm/rev.	
Gear ratio	69.12:1	69.12:1	69.12:1		
Nominal motor power	2	2	2	W	
Motor voltage	12	12	12	V	
Weight	0.16	0.22	0.26	kg	

Recommended motor controllers C-842, C-844, C-860 C-842, C-844, C-860 C-842, C-844, C-860

D2

* Higher forces on request

M-230 Servo & Stepper Motor Actuators

High-Resolution Closed-Loop DC-Mike & Stepper Actuators



M-230.10, M-230.25, high-resolution DC-Mike actuators, 10 and 25 mm travel range

- 10 & 25 mm Travel Range
- 0.05 μm Minimum Incremental Motion
- Non-Rotating Tip
- Velocity to 2 mm/sec.
- Closed-Loop DC Motors and Stepper Motors
- Compatible with Leading Industrial Motion Controllers
- Integrated Hall-Effect Origin and Limit Switches
- Front Mount or Clamp Mount
- >5,000 Hours MTBF

M-230 are ultra-high-resolution linear actuators providing linear motion up to 25 mm with sub-micron resolution in a compact package. They consist of a micrometer with non-rotating tip driven by a 2-phase stepper motor or a closed-loop DC motor/gearhead combination with motor-shaft-mounted, high-resolution encoder (2048 counts/rev.).

Non-Rotating Tip

Compared to conventional rotating-tip micrometer drives, the non-rotating-tip design offers several advantages:

- Elimination of torque-induced positioning errors
- Elimination of sinusoidal motion errors
- Elimination of wear at the contact point
- Elimination of tip-angle-dependent wobble

M-230 actuators provide a cost-effective solution for heavier-duty industrial and OEM environments. They feature extremely low-stiction, low-friction construction, allowing for minimum incremental motion as low as 50 nanometers and speeds up to 2 mm/sec.

Non-Contact Limit and Origin Switches

Integrated, non-contact, high-precision Hall-effect origin and limit switches protect your equipment and increase versatility in automation applications.

Integrated Line Drivers

M-230 actuators include an integral 0.5 m cable with 15-pin sub-D connector and a 3 m extension cable. On the DC-servo versions, the connector

features integrated line drivers for cable lengths up to 10 meters between actuator and controller.

A screw-in ball tip and a flat tip are included.

For higher loads and travel ranges refer to the M-235 on page 7-82.

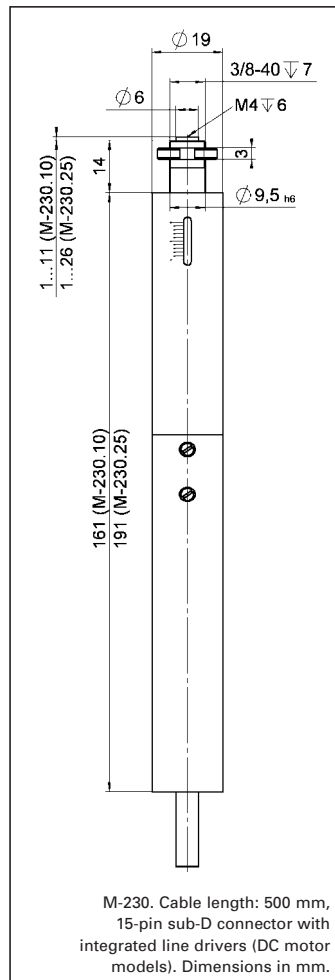

Ordering Information

M-230.10
DC-Mike Actuator, 10 mm, Limit Switches

M-230.25
DC-Mike Actuator, 25 mm, Limit Switches

M-230.10S
Stepper-Mike Actuator, 10 mm, Limit Switches

M-230.25S
Stepper-Actuator, 25 mm, Limit Switches

Ask about custom designs!

Application Examples

- Photonics packaging
- Fiber alignment
- Quality control
- Test equipment
- Metrology

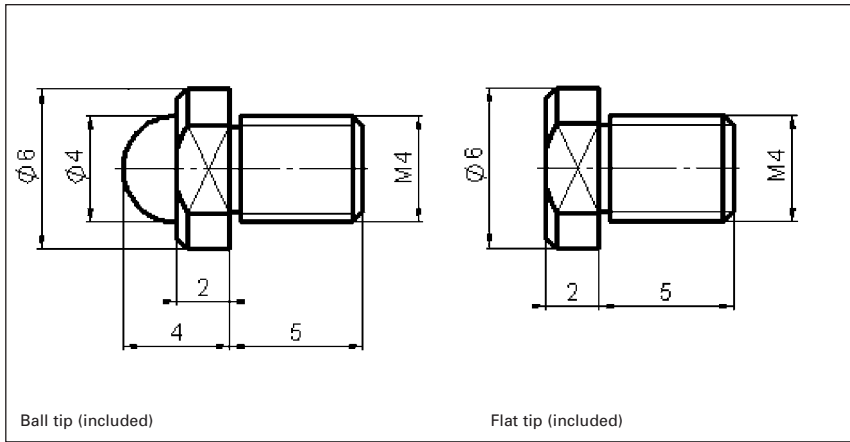

Technical Data

Models	M-230.10	M-230.25	M-230.10S	M-230.25S	Units	Notes see page 7-106
Travel range	10	25	10	25	mm	
Design resolution	0.0046	0.0046	0.0012	0.0012	µm	A3
Min. incremental motion	0.05	0.05	0.05	0.05	µm	A4
Unidirectional repeatability	0.1	0.1	0.1	0.1	µm	
Backlash	2	2	2	2	µm	
Max. velocity	1.5	1.5	2	2	mm/s	
Max. push/pull force	70	70	45**	45**	N	
Max. lateral force	30	20	30	20	N (at tip)	
Encoder resolution	2048	2048	-	-	counts/rev.	
Motor resolution	-	-	1200*	1200*	steps/rev.	
Drivescrew pitch	0.4	0.4	0.4	0.4	mm/rev.	
Gear ratio	42.92:1	42.92:1	28.44444:1	28.44444:1		
Nominal motor power	2	2	*	*	W	
Motor voltage	12	12	24*	24*	V	
Origin and limit switches	Hall-Effect	Hall-Effect	Hall-Effect	Hall-Effect		
Weight	0.30	0.35	0.30	0.35	kg	
Recommended motor controllers	C-843, C-848, C-862	C-843, C-848, C-862	C-600, C-630	C-600, C-630		D2

C-815.38 motor cable included: 3 m, sub-D, 15/15 pin (m/f).
 * 2-phase stepper, 24 V chopper voltage, max. 250 mA / phase, 1,200 microsteps with C-600, C-630 controllers
 ** at up to 1 mm/sec.

M-231 Servo Motor Actuator

High-Resolution Closed-Loop DC-Mike Actuators



M-231.17 high-resolution DC-Mike actuator, 17 mm travel range

- 17 mm Travel Range
- 0.1 μm Minimum Incremental Motion
- Velocity up to 2.5 mm/sec.
- Closed-Loop DC Motor
- Compatible with Leading Industrial Motion Controllers
- Integrated Hall-Effect Origin and Limit Switches
- Fits M-105 & F-110 Fiber Aligners
- >5,000 Hours MTBF

The M-231 is an ultra-high-resolution linear actuator providing linear motion up to 17 mm with sub-micron resolution in a compact package. It consists of a leadscrew which is driven by a closed-loop DC motor/gear-head combination with motor-shaft-mounted, high-resolution encoder (2048 counts/rev.).

Upgrade for Manual Aligners

The M-231 was especially designed to fit existing manual translation stages (e.g. M-105, see page 7-30) and F-110 piezo-electric fiber alignment systems (see page 8-24 in the "Photonics" section) as a direct replacement for a manual micrometer.

M-231 actuators provide a cost-effective solution in industrial and OEM environments. They feature a low-stiction low-fric-

tion construction allowing for minimum incremental motion of 100 nanometers at speeds up to 2.5 mm/sec.

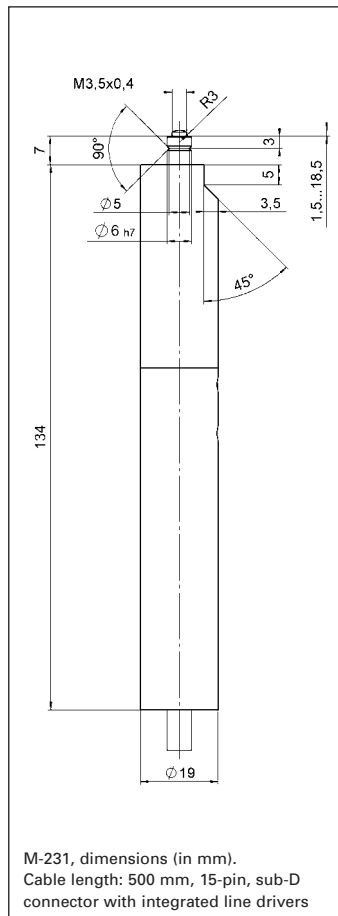

Non-Contact Limit and Origin Switches

Integrated, non-contact, high-precision Hall-effect origin and limit switches protect your equipment and increase versatility in automation applications.

Integrated Line Drivers

Each actuator includes an integral 0.5 m cable with 15-pin

sub-D connector and a 3 m extension cable. The connector features integrated line drivers for cable lengths up to 10 meters between actuator and controller.

Stepper-motor-driven versions of the M-231 are available on request.

For higher loads and travel ranges, refer to the M-230 and M-235 on pages 7-78 and 7-82.



M-231 mounted on M-105 XYZ positioning systems

Technical Data

Models	M-231.17	Units	Notes see p. 7-106
Travel range	17	mm	
Design resolution	0.007	μm	A3
Min. incremental motion	0.1	μm	A4
Unidirectional repeatability	0.2	μm	
Backlash	2	μm	
Max. velocity	2.5	mm/s	
Max. push/pull force	40	N	
Max. lateral force	0	N (at tip)	
Encoder resolution	2048	counts/rev.	
Drive screw pitch	0.4	mm/rev.	
Gear ratio	28.44444:1		
Nominal motor power	2	W	
Motor voltage	12	V	
Weight	0.17	kg	
Recommended motor controllers	C-843, C-848, C-862		D2

Ordering Information

M-231.17
DC-Mike Actuator, 17 mm,
Limit Switches

Ask about custom designs!

Application Examples

- Photonics packaging
- Fiber alignment
- Quality control
- Test equipment
- Metrology

M-232 Servo Motor Actuator

Compact, High-Resolution, Closed-Loop DC-Mike Actuator



M-232.17 high-resolution DC-Mike actuator mounted on M-105 translation stage

- 17 mm Travel Range
- 0.1 μm Minimum Incremental Motion
- Velocity up to 2.5 mm/sec.
- Closed-Loop DC Motor
- Compatible with Leading Industrial Motion Controllers
- Integrated Hall-Effect Limit and Origin Switches
- Fits M-105 & F-110 Fiber Aligners
- >5,000 Hours MTBF

The M-232 is an ultra-high-resolution linear actuator providing linear motion up to 17 mm with sub-micron resolution in a compact package. It features a space-saving design with a leadscrew side-by-side to a closed-loop DC motor / gear-head combination and a high-resolution encoder (2048 counts/rev.).

Upgrade for Manual Stages

The M-232 was especially designed to fit existing manual translation stages (e.g. M-105) and F-110 piezoelectric fiber alignment systems as a direct replacement for a manual micrometer. M-232 actuators provide a cost-effective solution in industrial and OEM

environments. They feature a low-stiction, low-friction construction allowing for minimum incremental motion of 100 nanometers at speeds of up to 2.5 mm/sec.

Non-Contact Limit and Origin Switches

Integrated, non-contact, high-precision Hall-effect origin and limit switches, protect your equipment and increase versatility in automation applications.

Technical Data

Models	M-232.17	Units	Notes see p. 7-106
Travel range	17	mm	
Design resolution	0.007	μm	A3
Min. incremental motion	0.1	μm	A4
Unidirectional repeatability	0.2	μm	
Backlash	2	μm	
Max. velocity	2.5	mm/s	
Max. push/pull force	40	N	
Max. lateral force	0	N (at tip)	
Encoder resolution	2048	counts/rev.	
Drive screw pitch	0.4	mm/rev.	
Gear ratio	28.44444:1		
Nominal motor power	2	W	
Motor voltage	12	V	
Limit switches	Hall-Effect		
Weight	0.17	kg	
Recommended motor controllers	C-843, C-848, C-862		D2

Ordering Information

M-232.17
Compact DC-Mike Actuator,
17 mm, Limit Switches

Ask about custom designs!

Integrated Line Drivers

Each actuator includes an integral 0.5 m cable with 15-pin sub-D connector and a 3 m extension cable. The connector features integrated line drivers for cable lengths up to 10 meters between actuator and controller.

Stepper-motor-driven versions of the M-232 are available on request. For higher loads and travel ranges refer to the M-230 and M-235 datasheets on pages 7-68 and 7-72.

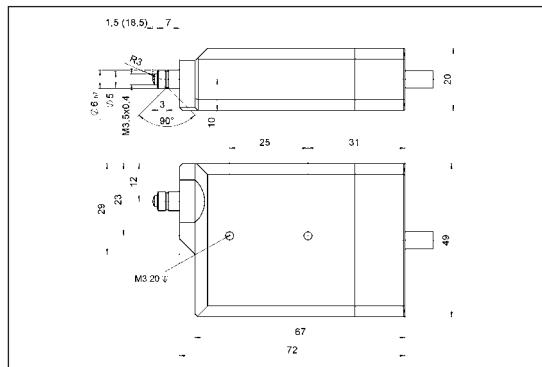

Index

M-232, dimensions (in mm). Cable length: 500 mm, 15-pin sub-D connector with integrated line drivers.

Application Examples

- Photonics packaging
- Fiber alignment
- Quality control
- Test equipment
- Metrology

M-235 Servo & Stepper Motor Actuators

Heavy-Duty High-Resolution Closed-Loop DC-Mike & Stepper Actuators



M-235.2DG (top) and M-235.5DG (bottom) high-resolution DC-Mike, ballscrew.

- 20 mm or 50 mm Travel Range
- 0.1 μm Minimum Incremental Motion
- High-Speed Direct Drive Option
- 120 N Push/Pull Load
- 100 N Lateral Load Limit
- Preloaded Ultra-Low-Friction Ball Screw with Non-Rotating Tip
- Closed-Loop DC Motors and Stepper Motors
- Compatible with Leading Industrial Motion Controllers
- Integrated Hall-Effect Limit & Origin Switches
- >20,000 Hours MTBF
- Vacuum Versions

The M-235 is an ultra-high-resolution linear actuator providing linear motion of up to 50 mm with sub-micron resolution in a compact package. It consists of a preloaded ultra-low-friction, heavy-duty ballscrew which is driven by a 2-phase stepper motor or a closed-loop DC motor with motor-shaft-mounted, high-resolution encoder (2048 counts/rev.).

Application Examples

- Quality control
- Test equipment
- Flexible automation
- Metrology
- Photonics packaging
- Fiber alignment

Non-Rotating Tip

Compared to conventional rotating-tip micrometer drives, the non-rotating-tip design offers several advantages:

- Elimination of torque-induced positioning errors
- Elimination of sinusoidal motion errors
- Elimination of wear at the contact point
- Elimination of tip-angle-dependent wobble

M-235 actuators provide a cost-effective solution for heavy-duty industrial and OEM environments. They feature an extremely low stiction, low-friction construction, allowing for minimum incremental motion as low as 100 nanometers. The M-235.5DD version is equipped with a direct drive motor for

high-speed positioning applications.

Non-Contact Limit and Origin Switches

Integrated, non-contact, high-precision Hall-effect origin and limit switches, protect your equipment and increase versatility in automation applications.

Integrated Line Drivers

M-235 actuators with DC motors include an integral 0.5 m cable with 15-pin sub-D connector and a 3 m extension cable. The connector features integrated line drivers for cable lengths up to 10 meters between actuator and controller.

A screw-on ball tip and a flat tip are included.

For smaller sizes and lower-duty applications, refer to the M-230, M-231, M-232 and M-227 and M-168 see p. 7-76, p. 7-78, p. 7-80, p. 7-81, and p. 7-84.

Ordering Information

- M-235.2DG**
Heavy-Duty, High-Resolution DC-Mike Actuator, 20 mm, Ballscrew, Limit Switches
 - M-235.2VG**
Vacuum Version of M-235.2DG
 - M-235.2DD**
Heavy-Duty, High-Resolution DC-Mike Actuator, Direct Drive, 20 mm, Ballscrew, Limit Switches
 - M-235.2VD**
Vacuum Version of M-235.2DD
 - M-235.22S**
Heavy-Duty, High-Resolution Stepper-Mike Actuator, 20 mm, Ballscrew, Limit Switches
 - M-235.5DG**
Heavy-Duty, High-Resolution DC-Mike Actuator, 50 mm, Ballscrew, Limit Switches
 - M-235.5VG**
Vacuum Version of M-235.5DG
 - M-235.5DD**
Heavy-Duty, High-Resolution DC-Mike Actuator, Direct Drive, 50 mm, Ballscrew, Limit Switches
 - M-235.5VD**
Vacuum Version of M-235.5DD
 - M-235.52S**
Heavy-Duty, High-Resolution Stepper-Mike Actuator, 50 mm, Ballscrew, Limit Switches
- Higher speed M-235 versions on request**
- Ask about custom designs!**



M-235.52S high-resolution Stepper-Mike, 50 mm travel range, ballscrew.

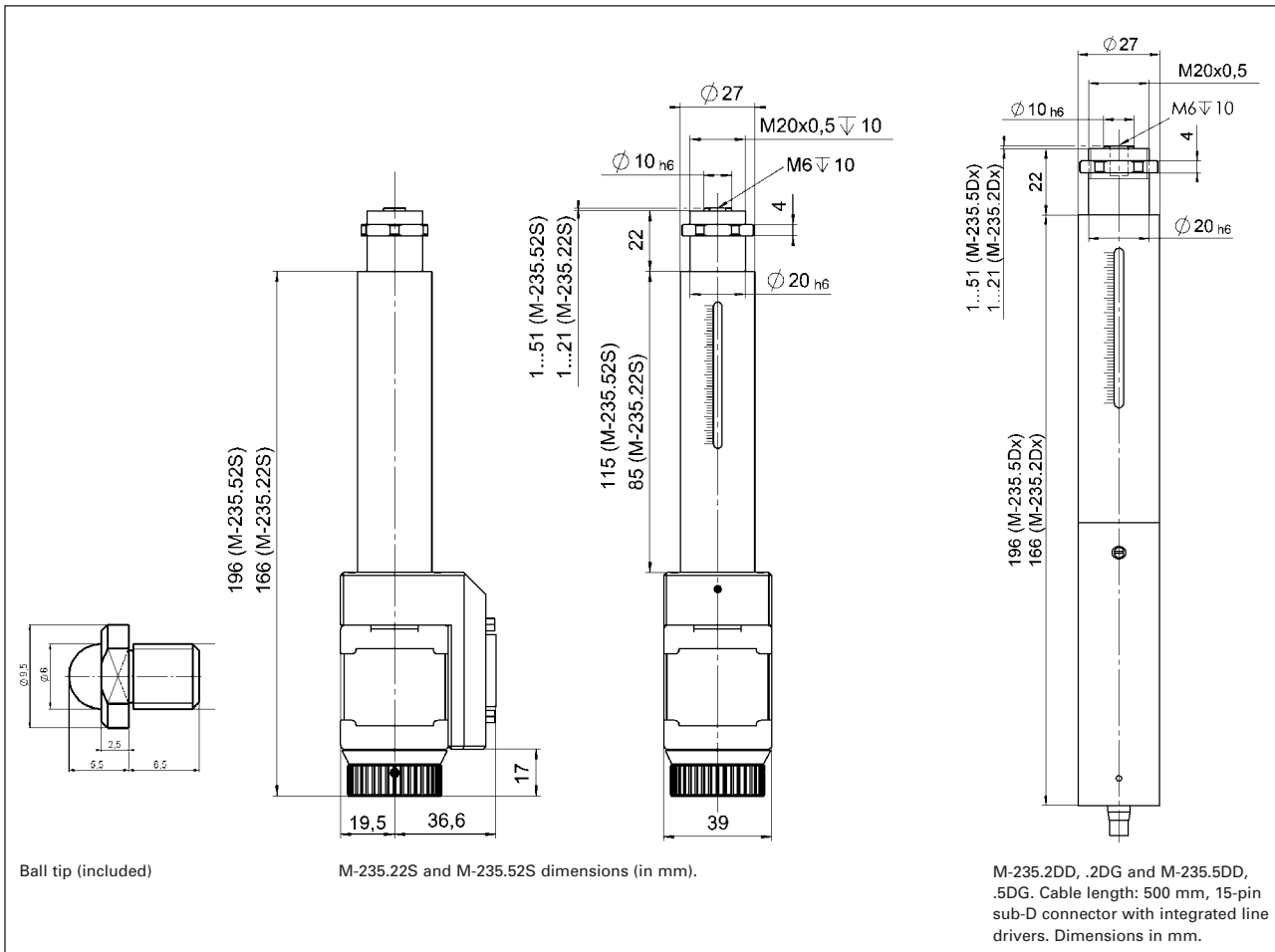

Technical Data

Models	M-235.2DG	M-235.2DD	M-235.22S	M-235.5DG	M-235.5DD	M-235.52S	Units	Notes see page 7-106
Travel range	20	20	20	50	50	50	mm	
Design resolution	0.016	0.5	0.05	0.016	0.5	0.05	μm	A3
Min. incremental motion	0.1	0.5	0.1	0.1	0.5	0.1	μm	A4
Unidirectional repeatability	0.1	0.5	0.2	0.1	0.5	0.2	μm	
Bidirectional repeatability	1	1	1	1	1	1	μm	
Max. velocity	3	>30	20	3	>30	20	mm/s	
Max. push/pull force	120	>50	100**	120	>50	100**	N	
Max. lateral force (at tip)	100	100	100	100	100	100	N	
Encoder resolution	2048	2048	-	2048	2048	-	counts/rev.	
Motor resolution	-	-	20,000*	-	-	20,000*	steps/rev.	
Ballscrew pitch	1	1	1	1	1	1	mm/rev.	
Gear ratio	29.6:1	-	-	29.6:1	-	-		
Nominal motor power	4	17	- *	4	17	-*	W	
Motor voltage	12	12	24 *	12	12	24 *	V	
Origin and limit switches	Hall-Effect	Hall-Effect	Hall-Effect	Hall-Effect	Hall-Effect	Hall-Effect		
Mass	0.55	0.50	0.65	0.7	0.65	0.8	kg	
Recommended motor controllers	C-843, C-848, C-862	C-862	C-600, C-630	C-843, C-848, C-862	C-862	C-600, C-630		D2

C-815.38 motor cable included: 3 m, sub-D, 15/15 pin (m/f).

* 2-phase stepper, 24 V chopper voltage, max. 0.8 A / phase, 20,000 microsteps with C-600, C-630 controllers. ** at up to 10 mm/sec

M-238 Servo Motor Actuators

High-Load, High-Resolution Linear Actuator with Optional Linear Encoder



M-238.5PL Heavy-Duty Mike actuator (with CD for size comparison)

- High Load Capacity to 400 N
- Travel Range 50 mm
- Resolution to 0.1 μm
- Max. Velocity 30 mm/s
- Preloaded Frictionless Ball Screw
- Optional 0.1 μm Direct-Metrology Linear Encoder for Exceptional Precision
- MTBF >20,000 h
- Vacuum-Compatible Versions Available for 10⁻⁶ hPa

The M-238 is a high-load, high-precision actuator providing linear motion up to 50 mm, a load capacity to 400 N and high velocity to 30 mm/s. It consists of a low-friction, heavy-duty ballscrew, driven by a closed-loop, ActiveDrive™ DC-Motor with gearbox. The M-238 is therefore well suited for high duty-cycle operation in industrial environments. An optional linear encoder provides exceptional accuracy and repeatability.

Application Examples

- Quality assurance testing
- Testing equipment
- Precision machining
- Astronomy
- Flexible automation
- Metrology

Direct Metrology Linear Encoder to Compensate Mechanical Play

The M-238.5PL model is equipped with a non-contact, optical, linear encoder (direct metrology) with an output resolution of 0.1 μm . Because the encoder measures the actual position of the non-rotating actuator tip, drive-train errors like backlash and elastic deformations are eliminated. A lower-cost version with a rotary encoder is available as model number M-238.5PG.

ActiveDrive™ DC-Motor

DC motor drives offer several advantages, such as high dynamics, high torque at low rotational speed, low heat and low vibration.

The ActiveDrive™ design, developed by PI, features a

high-efficiency PWM (pulse width modulation) servo-amplifier mounted side-by-side with the DC-Motor and offers several advantages:

- Increased efficiency, by eliminating power losses between the amplifier and motor
- Reduced cost of ownership and improved reliability, because no external driver is required
- Elimination of PWM amplifier noise radiation, by mounting the amplifier and motor together in a single, electrically shielded case

Non-Rotating Tip

Compared to conventional rotating-tip micrometer drives, the non-rotating-tip design offers several advantages:

- Elimination of torque-induced positioning errors
- Elimination of sinusoidal motion errors
- Elimination of wear at the contact point
- Elimination of tip-angle dependent wobble

The lateral guiding of the tip withstands lateral forces of up to 100 N.

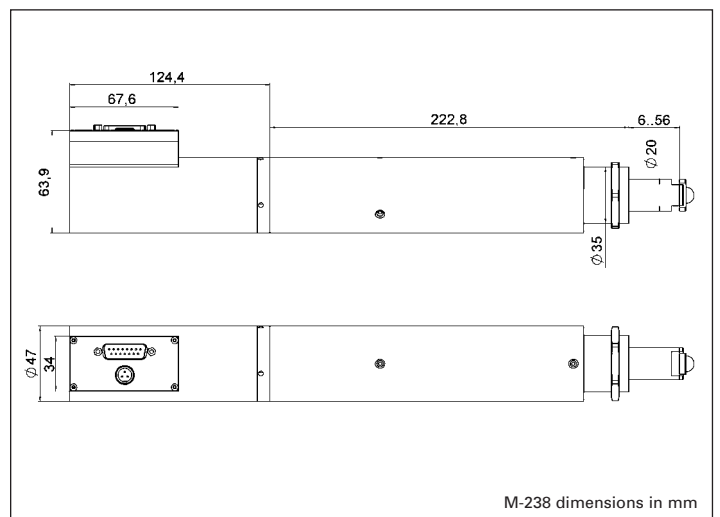

M-238 dimensions in mm

Ordering Information

M-238.5PG
Heavy-Duty DC-Mike Actuator, 400 N, 50 mm, ActiveDrive™

M-238.5PL*
Heavy-Duty DC-Mike Actuator, 400 N, 50 mm, ActiveDrive™, Direct-Metrology Encoder

* Ask for availability in your region

Ballscrews for High Speed, Precision and Lifetime

The precision-ground ballscrew is maintenance-free and preloaded to eliminate mechanical play. Its significantly reduced friction, compared to conventional leadscrews, allows for higher velocity, lower power consumption and longer lifetime.

Limit and Reference Switches

For the protection of your equipment, non-contact Hall-effect limit and reference switches are installed. The direction-sensing reference switch supports advanced automation applications with high precision.

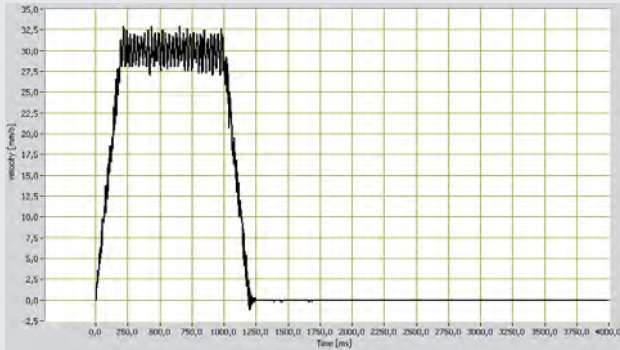

M-238.5PL velocity at 30 mm/s is highly constant.

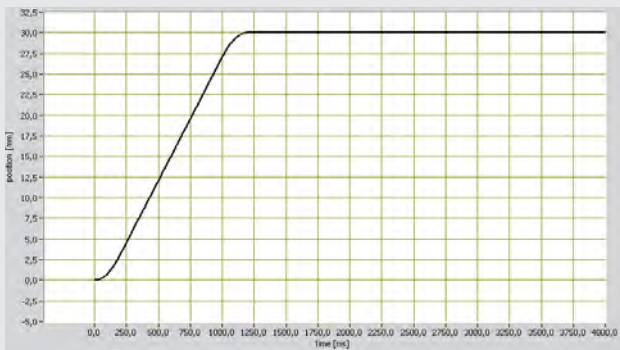

The settling time for a 30 mm step is less than 1.5 seconds.

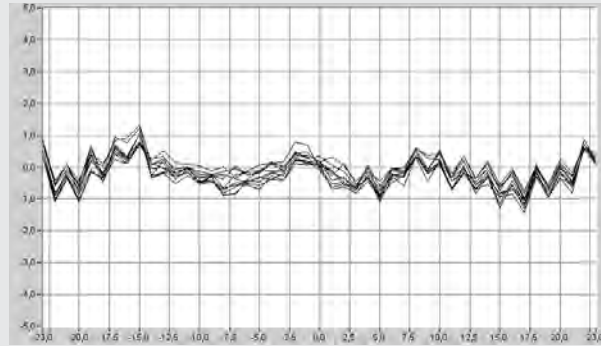
M-238.5PL repeatability is better than 0.3 μm .

Technical Data

Models	M-238.5PG	M-238.5PL	Units	Tolerance
Active axes	X	X		
Motion and positioning				
Travel range	50	50	mm	
Integrated sensor	Rotary encoder	Linear encoder		
Sensor resolution	4000 cts/rev.	0.1 μm		
Design resolution	0.13	0.1	μm	typ.
Min. incremental motion	0.5	0.3	μm	typ.
Backlash	3	1	μm	typ.
Unidirectional repeatability	1	0.3	μm	typ.
Max. velocity	30	30	mm/s	
Origin repeatability	1	1	μm	$\pm 20\%$
Mechanical properties				
Spindle pitch	2	2	mm/rev.	
Gear ratio	3.71:1	3.71:1		
Push/pull force	400	400	N	Max.
Lateral force	100	100	N	Max.
Drive properties				
Motor type	DC-motor, ActiveDrive™	DC-motor, ActiveDrive™		
Operating voltage	24 (PWM)	24 (PWM)	V	
Electrical power	80	80	W	nominal
Miscellaneous				
Operating temperature range	-10 to 50	-10 to 50	$^{\circ}\text{C}$	
Material	Al (anodized), steel	Al (anodized), steel		
Mass	2.4	2.4	g	$\pm 5\%$
Cable length	3	3	m	$\pm 10\text{ mm}$
Connector	D-Sub 15 (m)	D-Sub 15 (m)		
Recommended controller/driver	C-862, C-843	C-862, C-843		

M-122 Servo Motor Linear Slide

Fast Miniature Linear Translation Stage with Integrated Optical Linear Encoder



The M-122.2DD miniature translation stage features an optical linear encoder with 0.1 μm position resolution and a highly efficient ballscrew



- Travel Range 25 mm
- 0.1 μm Optical Linear Encoder for Highest Accuracy & Repeatability
- Min. Incremental Motion to 0.2 μm
- Max. Velocity 20 mm/s
- Cross-Roll Bearings
- Recirculating Ball Screw Drives Provide High Speeds & Long Lifetimes

The M-122 palm-top-sized translation stage combines small dimensions, high speeds and very high accuracy at a competitive price. It features a space-saving, folded drive train with the servo motor and drive screw side-by-side. Equipped with a non-contacting optical linear encoder and a preloaded, precision-ground, ball-screw, these stages can provide much higher accuracy and better repeatability than conventional stepper motor stages or rotary encoder-equipped servo motor stages.

Low Friction, High Speed, Maintenance-Free

Due to its low-friction, the backlash-free ball screw yields significantly higher mechanical

efficiency than leadscrews, and allows maintenance-free, high duty-cycle operation at high velocities up to 20 mm/sec.

XY and XYZ Combinations

M-122 stages can be combined to very compact XY and XYZ systems. The M-122.AP1 mounting bracket is available to mount the Z-axis.

Limit and Reference Switches

For the protection of your equipment, non-contact Hall-effect limit and reference switches are installed. The direction-sensing reference switch supports advanced automation applications with high precision.

Low Cost of Ownership

The combination of these positioners with the networkable, single-channel C-862 Mercury™ servo motor controller (s. p. 9-6) offers high performance for a very competitive price in both single- and multi-axis configurations. For multi-axis applications, the C-843 PC plug-in controller board with on-board servo amplifiers (s. p. 9-8) is another cost-effective alternative.

Ordering Information

M-122.2DD
High-Precision Translation Stage, 25 mm, Direct-Drive DC Motor, Ballscrew

Accessories

M-122.AP1
Angle bracket for vertical mounting of M-122 stages
Ask about custom designs

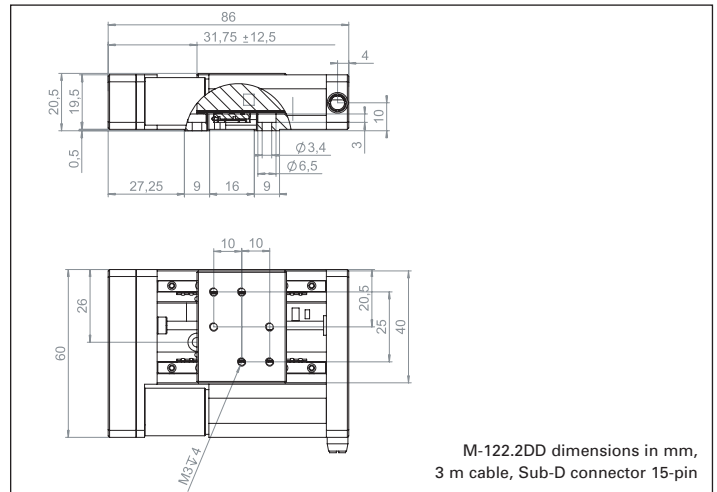

M-122.2DD dimensions in mm, 3 m cable, Sub-D connector 15-pin

Technical Data

	M-122.2DD
Active axes	X
Motion and positioning	
Travel range	25 mm
Integrated sensor	Linear encoder
Sensor resolution	0.1 μm
Design resolution	0.1 μm
Min. incremental motion	0.2 μm
Backlash	0.2 μm
Unidirectional repeatability	0.15 μm
Pitch	$\pm 150 \mu\text{rad}$
Yaw	$\pm 150 \mu\text{rad}$
Max. velocity	20 mm/s
Origin repeatability	1 μm
Mechanical properties	
Drive screw	Recirculating ballscrew
Thread pitch	0.5 mm
Stiffness in motion direction	0.25 N/ μm
Max. load	50 N
Max. push/pull force	20 N
Max. lateral force	25 N
Drive properties	
Motor type	DC motor
Operating voltage	0 to $\pm 12 \text{ V}$
Electrical power	2.25 W
Limit and reference switches	Hall-effect
Miscellaneous	
Operating temperature range	-20 to +65
Material	Aluminum, steel
Dimensions	86 x 60 x 20.5 mm
Mass	0.22 kg
Recommended controller/driver	C-862 (single-axis) C-843 PCI board (up to 4 axes)

Application Examples

- Photonics packaging
- Fiber positioning
- Metrology
- Quality assurance testing
- Testing equipment
- Micromachining

M-413 Servo & Stepper Motor Linear Slides

High-Load Translation Stages for Cost-Sensitive Precision Positioning Applications



M-413 linear stage versions (from right: the M-413.1PD, M-413.2PD and M-413.3PD provide travel ranges from 100 to 300 mm (CD for size comparison)

- For Cost-Sensitive Precision Positioning Applications
- Travel Ranges 100 to 300 mm
- Resolution to 0.018 µm
- Min. Incremental Motion to 0.1 µm
- Preloaded Precision Leadscrew or Recirculating Ball Screw Drives Provide High Speeds & Long Lifetimes
- Stress-Relieved Aluminum Base for Highest Stability
- Vacuum-Compatible Versions Available
- M-413 and M-414 Versions for Reduced Load Requirements

The M-413 and M-414 linear translation stage series provide cost effective solutions for precision positioning of higher loads up to 50 kg over travel ranges up to 300 mm.

They are designed with a precision-machined, high-density, stress-relieved aluminum base for exceptional stability and robustness. The highly precise M-413 drive includes a preloaded leadscrew, providing a minimum incremental motion of 0.2 µm.

High Resolution Ball Screws & Lead Screws

For higher velocities and a long lifetime the M-414 versions fea-

Application Examples

- Automation
- R&D
- Semiconductor technology
- Metrology
- Quality assurance testing

ture a low-friction ball screw offering a minimum incremental motion down to 0.1 µm. Three motor drive options allow the optimum adaptation to the requirements of different automation applications.

M-413s and M-414s are available in 3 lengths providing travel ranges from 100 to 300 mm. The stages can carry up to 50 kg and push/pull up to 50 N. Special versions for vacuum applications are available (see ordering information).

Maintenance-Free, High Guiding Precision

All models are equipped with high-precision linear guiding rails and recirculating ball bearings. The recirculating ball bearings are maintenance free and immune to cage migration. The choice of components and careful mounting guarantees high load capacity, longer lifetime and high guiding accuracy. Additionally the bearings

Ordering Information

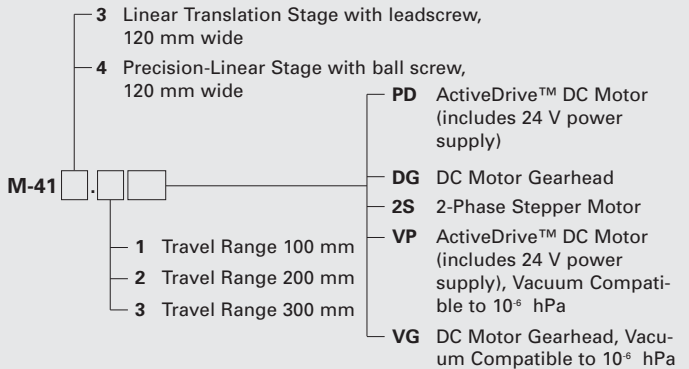

are polished to guide the carriage with optimum straightness and flatness.

Low Cost of System Ownership

The combination of these stages with the networkable single-axis C-862 Mercury™ (s. p. 9-6) and C-663 Mercury™ Step controllers offers high performance for a very competitive price in both single and multi-axis configurations. Alternatively, the C-843 motion controller PCI card with on-board servo amplifiers (!) is available.

Three Motor Drive Options

M-41x.xPD high-speed versions come equipped with the high-performance ActiveDrive™ system. The ActiveDrive™ design, developed by PI, features a high-efficiency PWM (pulse width modulation) servo-amplifier mounted side-by-side with the DC motor and offers several advantages:

- Increased efficiency, by eliminating power losses between the amplifier and motor
- Reduced cost of ownership and improved reliability, because no external driver is required
- Elimination of PWM amplifier noise radiation, by mounting the amplifier and motor

together in a single, electrically shielded case

M41x.xDG models are equipped with a DC motor with a low-backlash gearhead and a shaft-mounted optical encoder to give a minimum incremental motion of 0.1 µm.

M-41x.x2S models feature a cost-effective direct-drive, 2-phase stepper motor, providing very smooth operation and a resolution of 0.2 µm.

Limit and Reference Switches

For the protection of your equipment, non-contact Hall-effect limit and reference switches are installed. The direction-sensing reference switch supports advanced automation applications with high precision.

Other Family Members

The M-403/M-413 and M-404/M-414 series of linear stages form a modular system. The M-403 is the basic family, providing travel ranges from 25 to 200 mm. M-413 is designed for higher loads with travel ranges from 100 to 300 mm. The M-404 and M-414 stages have the same travel ranges and load capacities, but offer higher precision and more speed.^e

© PI 1998-2007. Subject to change without notice. This data sheet is superseded by any new release. The newest release is available for download at www.pi.ws, 07/06/22.0.2

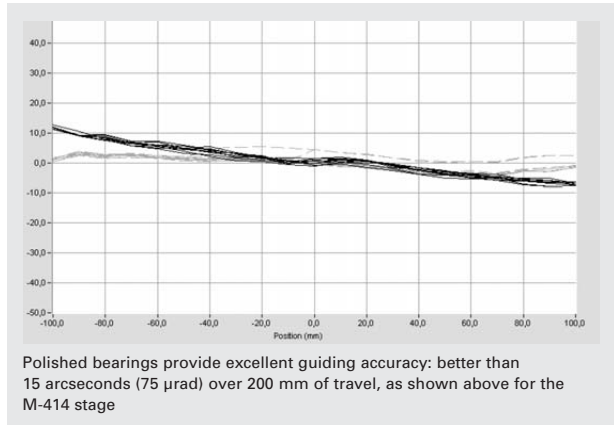
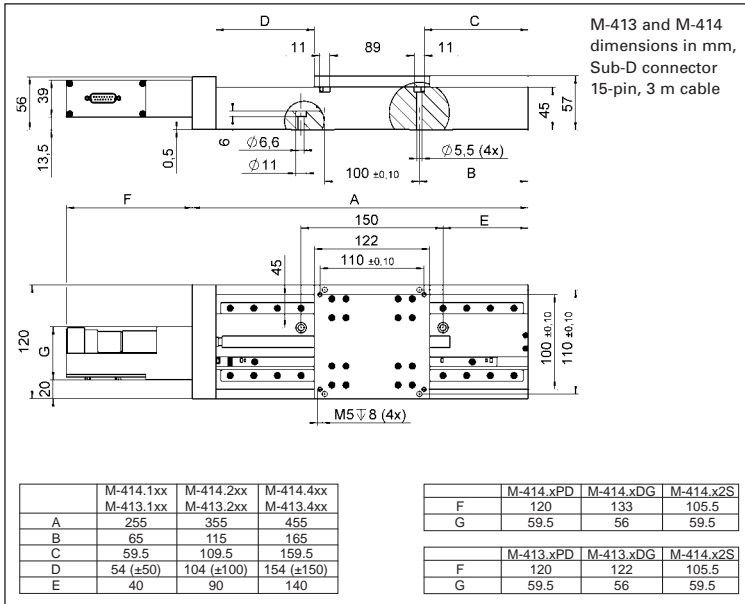

Technical Data

	M-414.xPD	M-414.xDG	M-414.x2S	M-413.xPD	M-413.xDG	M-413.x2S	Units
Motion and positioning							
Travel range	for all models: 100 / 200 / 300 mm (see Ordering Information)						
Integrated sensor	Rotary encoder	Rotary encoder	—	Rotary encoder	Rotary encoder	—	
Sensor resolution	4000	2000	—	4000	2000	—	cts/rev.
Design resolution	0.5	0.023	0.31	0.25	0.018	0.16	μm
Min. incremental motion	0.5	0.1	0.4	0.25	0.2	0.2	μm
Backlash	0.5	4	2	6	10	6	μm
Unidirectional repeatability	0.5	1	1	1	1	1	μm
Pitch	100	100	100	300	300	300	μrad
Yaw	100	100	100	300	300	300	μrad
Max. velocity	100	3	6	10*	2.5	3	mm/s
Origin repeatability	1	1	1	1	1	1	μm
Mechanical properties							
Spindle	Recirculating ballscrew	Recirculating ballscrew	Recirculating ballscrew	Leadscrew	Leadscrew	Leadscrew	
Spindle pitch	2	2	2	1	1	1	mm
Gear ratio	—	42.92063:1	—	—	28.44444:1	—	
Motor resolution	—	—	6400*	—	—	6400*	steps/rev.
Stiffness in motion direction	6000	6000	6000	6000	6000	6000	N/μm
Max. load	500	500	500	500	500	500	N
Max. push/pull force	50	50	50	50	50	50	N
Max. lateral force	200	200	200	200	200	200	N
Drive properties							
Motor type	ActiveDrive™ DC motor	DC motor, gearhead	2-phase stepper motor*	ActiveDrive™ DC motor	DC motor, gearhead	2-phase stepper motor*	
Operating voltage	24	0–12	24	24	0–12	24	V
Electrical power	70	3.6	4.8	70	3.6	4.8	W
Torque	80	3	200	80	3	200	Ncm
Limit and reference switches	Hall-effect	Hall-effect	Hall-effect	Hall-effect	Hall-effect	Hall-effect	
Miscellaneous							
Operating temperature range	-20 to +65	-20 to +65	-20 to +65	-20 to +65	-20 to +65	-20 to +65	°C
Material	for all models: Aluminum (black anodized)						
Mass (depends on dimensions/travel range)	4.4 / 5.4 / 6.6	4.2 / 5.2 / 6.4	4.4 / 5.4 / 6.6	4.4 / 5.4 / 6.6	4.2 / 5.2 / 6.4	4.4 / 5.4 / 6.6	kg
Recommended controller/driver	C-862 (single-axis) C-843 PCI board (up to 4 axes)	C-862 (single-axis) C-843 PCI board (up to 4 axes)	C-663 (single-axis)	C-862 (single-axis) C-843 PCI board (up to 4 axes)	C-862 (single-axis) C-843 PCI board (up to 4 axes)	C-663 (single-axis)	

*2-phase stepper motor, 24 V chopper voltage, max. 0.8 A/phase, 400 full steps/rev., motor resolution with C-663 stepper motor controller

* Max. recommended velocity

C-863 Controller for Servo Actuators

Mercury™ DC-Motor Controller / Driver with Network Feature



The C-863 Mercury™ DC servo controller features USB and RS-232 interfaces and incremental encoder signal processing at 20 MHz bandwidth

- High Performance at Low Cost
- DC Servo-Motor Controller Supplies up to 30 W
- 20 MHz Encoder Input for High Speed & Resolution
- Macro Programmable Stand-Alone Functionality
- Network Capability for Multi-Axis Applications
- Non-Volatile EEPROM for Macros and Parameters
- Digital I/O Lines (TTL)
- Motor-Brake Control
- USB and RS-232 Interface
- Optional Joystick for Manual Control
- Works with All PI Micropositioning Actuators and Stages

The latest generation Mercury™ C-863 servo motor controller is even more powerful and versatile than its predecessors. Easy data interchange with laptop or PC is possible via the USB interface. The RS-232 interface provides for easy integration in industrial applications. The compact design with its integrated amplifier makes it ideal for building high-performance,

cost-effective micropositioning systems.

Flexible Automation

The Mercury™ offers a number of features to achieve automation and handling tasks in research and industry in a very cost-effective way. Programming is facilitated by the high-level mnemonic command language with macro and compound-command functionality. Macros can be stored in the non-volatile memory for later recall.

Stand-alone capability is provided by a user-programmable autostart macro to run automation tasks at power up (no runtime computer communication required!).

For easy synchronization of motion with internal or external trigger signals four input and four output lines are provided.

Multi-Axis Control, Combination of DC & Stepper Motors

Up to 16 C-863 Mercury™ DC servo controllers and C-663 stepper motor controllers can be daisy-chained and addressed via the same interface.

The networking feature allows the user to start out with one controller and add more units later for multiaxis setups.

Easy Programming

All servo and stepper motor controllers of the Mercury™ family can be operated using the PI general command set (GCS). PI-GCS allows networking of different controller units, both for piezo-based and motorized positioning units, with minimal programming effort. In addition, the C-863 can be programmed using the native command set of previous Mercury™ controllers.

Cost-Saving Due to Integrated Amplifier and PWM Outputs

The unique Mercury™ concept combines a high-performance motion controller and an integrated power amplifier in a small package. Additional PWM control outputs allow the direct operation of any DC-motor-driven PI micro-positioning system—even high-speed stages such as the M-500 ActiveDrive™ Translation Stages—reducing costs, increasing reliability and simplifying the setup.

Contents of Delivery

Each controller is delivered with a wide-range power sup-

Ordering Information

C-863.10
Mercury™ DC-Motor Controller, 1 Channel, with Wide-Range Power Supply

Accessories:

C-819.20
2-Axis Analog Joystick for Mercury™ Controller

C-819.20Y
Y-Cable for Connecting 2 Controllers to C-819.20

C-862.PB3
Push Button Box for Mercury™

ply, RS-232 communication cable, a daisy-chain network cable and a comprehensive software package.

A stepper motor version is available as the C-663:

Stepper Motor Version

C-663.10
Mercury™ Step Stepper Motor Controller with Wide-Range Power Supply

C-663.PS
Wide-Range Power Supply for Mercury™ Step, 24 V

Application Examples

- Fiber positioning
- Automation
- Photonics / integrated optics
- Quality assurance testing
- Testing equipment

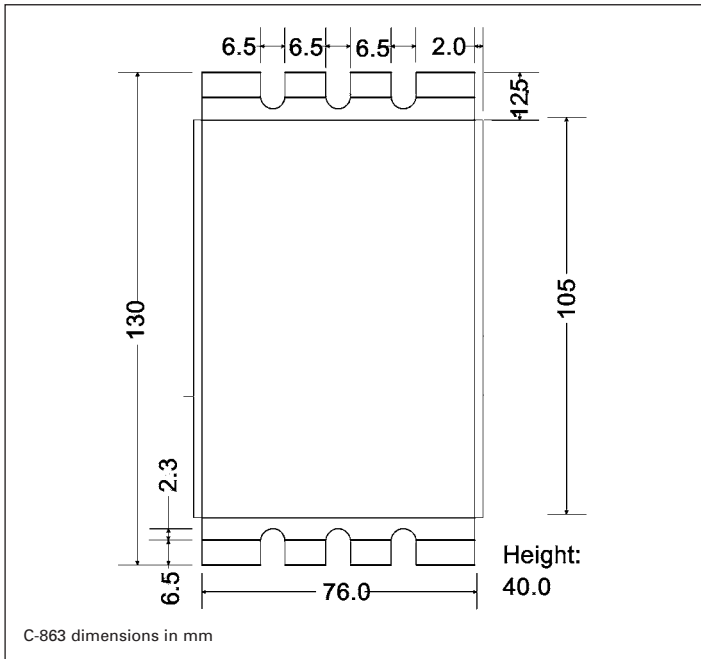

C-843 DC-motor controller board (center) with M-110 linear stage, M-235 linear actuator, M-511.DD translation stage and M-501.1DG vertical stage. No external amplifier is required to drive any of these or other PI stages. Small motors are driven through the C-843's onboard linear amplifiers, direct-drive stages (e.g. M-511.DD) employ ActiveDrive™ controlled off the C-843's PWM outputs.

Technical Data

Model	C-863.10
Function	DC-servo-motor controller, 1 channel
Motion and control	
Servo characteristics	P-I-D-amplifier, parameter change on-the-fly
Trajectory profile modes	Trapezoidal, point-to-point
Encoder input	AB (quadrature) single-ended or differential TTL signal, 20 MHz
Stall detection	Servo off, triggered by programmable position error
Input limit switch	2 x TTL (pull-up/pull-down, programmable)
Input reference switch	1 x TTL
Motor brake	1 x TTL, software controlled
Electrical properties	
Output power	max. 30 Watt (PWM)
Output voltage	0 to 15 V
Current	80 mA + motor current (3 A max.)
Interfaces and operation	
Communication interfaces	USB, RS-232 (9-pin [m] sub-D)
Motor connector	15-pin (f) sub-D
Controller network	Up to 16 units on single interface
I/O ports	4 analog/digital in, 4 digital out (TTL)
Command set	Mercury Command Set, GCS (via DLL)
User software	PIMikroMove®, MMCRun
Software drivers	GCS (PI General Command Set)-DLL, LabVIEW drivers, native Mercury™ DLL
Supported functionality	Start-up makro; internal safety circuitry: watchdog timer
Manual control (optional)	2-axis joystick, Y-cable for 2D motion, pushbutton box
Miscellaneous	
Operating voltage	15 to 30 V included: external power supply C-890.PS, 15 V / 2 A
Operating temperature range	+5 to +50 °C
Mass	0.3 kg
Dimensions	130 x 76 x 40 mm

C-867 Controller for PLine® Piezo Linear Drives Servo-Controller with Integrated Driver for High-Speed Ultrasonic Piezo Motors



C-867 piezomotor controller together with an extremely low-profile M-692 positioner with integrated piezoceramic PLine® linear drive

- Optimized for PLine® Ultrasonic Piezo Linear Motors
- High-Bandwidth Encoder Inputs Allow High Speed and Resolution
- PID Servo-Control with Dynamic Parameter Switching
- Integrated Piezo Motor Power Driver
- USB, RS-232 and Analog Interfaces (e. g. for Joystick)
- 4 + 4 Programmable TTL-I/Os for Flexible Automation
- Data Recorder
- Daisy-Chain Networking for up to 16 Axes
- Powerful Macro Programming Language, e. g. for Stand-Alone Operation
- Extensive Software Support, LabVIEW, DLL ...

The C-867 controller is especially designed for closed-loop positioning systems equipped with PLine® piezo linear motor drives. A compact case contains both drive electronics for the piezo ceramic motors and components for controlling and communication.

Application Examples

- Biotechnology
- Microscopy
- Fiber positioning
- Automation
- Photonics / integrated optics
- Quality assurance testing
- Testing equipment

The controller can be operated from a host PC either via a USB port or an RS-232 interface. Alternatively, a stand-alone operation is possible. Here, stored macro commands can be executed, or manual control by joystick or pushbutton box is possible.

Two models are available: C-867.160 is used to operate single-axis positioning systems, the two-channel C-867.260 is used with XY scanning stages.

Highly Specialized PID Servo-Controller

The C-867 is based on a highly specialized DSP (Digital Signal Processor) that handles the PID servo-control algorithm as well as other system functions.

Because of the motion properties typical for ultrasonic piezomotors, the controller has a number of advanced features, including dynamic control parameter adaption. By automatically switching between gainsets for dynamic and static operation an optimized settling behavior within a couple of 10 milliseconds is achieved. The broadband encoder input (50 MHz) allows high resolution encoders to be used with the outstandingly high accelerations and velocities that PLine® drives deliver.

Highest Stability by Frequency Control

The integrated piezomotor drive electronics support all PLine® ultrasonic piezomotors used for the M-66x to M-69x positioning stage series.

Drift in the mechanical frequency of the motor caused by temperature or load changes is automatically compensated by a frequency-control loop which adjusts the operating frequency of the driving voltage. This leads to the highest stability in pushing force, velocity and closed-loop control.

Software / Programming

In addition to the user software for setup, system optimization and operation, comprehensive LabVIEW and DLL libraries are provided.

The PIMikroMove™ user software provides the PITuningTool for optimizing system performance. Graphic displays show the system's behaviour and facilitate parameter setting.

Advantages of PLine® Micropositioning Systems

Positioning systems equipped with ceramic ultrasonic drives of the PLine® series provide

Ordering Information

C-867.160
Piezomotor Controller with Drive Electronics, Networkable, for PLine® Systems

C-867.260
Piezomotor Controller with Drive Electronics, 2 Channels, for PLine® Systems

Accessories:
C-819.20
Analog Joystick for 2 axes

C-819.20Y
Y-Cable for Connecting 2 Controllers to C-819.20

C-170.PB
Pushbutton Box, 4 Buttons and 4 LEDs

Ask about custom designs!

several advantages over positioners that apply classic drive technology:

- Smaller dimensions
- Higher holding force when powered down; no holding current
- Increased acceleration of up to 5 g
- Increased velocity of up to 500 mm/s or 720°/s
- No leadscrews, gears or other mechanical components, no wear or maintenance
- No lubricants
- Non-magnetic and vacuum-compatible operating principle

See www.pi.ws for other Ultrasonic Motor Controllers



The two-channel C-867.260 controller operates XY scanning stages, here:
a customized M-686 stage for microscopy

Technical Data

Model	C-867.160	C-867.260
Function	Controller and drive electronics for PLine® piezomotors / systems	
Drive type	PLine® motors, single and dual drives with P-661, P-664, U-161 or U-164	
Channels	1	2
Motion and control		
Servo characteristics	Programmable PID V-ff filter, parameter changes on the fly	
Trajectory profile modes	Trapezoidal	
Encoder input	A/B differential signals, 50 x 10° impulses/s	
Stall detection	Servo off, triggered by programmable position error	
Limit switch	2 x TTL per channel (programmable)	
Reference switch	1 x TTL per channel (active high / low, programmable)	
Electrical properties		
Max. output power / channel	15 W	
Max. output voltage / channel	200 V _{pp}	
Interfaces and operation		
Communication interfaces	USB, RS-232	
Motor connector	MDR14	2 x MDR14
Controller network	Up to 16 units on single interface	
I/O ports	4 analog/digital in, 4 digital out (Mini-DIN, 9-pin) digital: TTL analog: 0 to 5 V	
Command set	PI General Command Set (GCS)	
User software	PIMikroMove	
Software drivers	GCS-DLL, LabVIEW drivers	
Supported functionality	Start-up macro; macro; data recorder for recording parameters as motor input voltage, velocity, position or position error	
Manual control	Pushbutton box, joystick, Y-cable for control of 2 axes with joystick	Pushbutton box, joystick
Miscellaneous		
Operating voltage	24 VDC from external power supply (included)	
Current consumption	300 mA + motor current (2 A max.)	600 mA + motor current (4 A max.)
Operating temperature range	+5 °C to +40 °C	
Mass	1.0 kg	2.4 kg
Dimensions	206 x 130 x 66 mm (including mounting rails)	320 x 150 x 80.5 mm (including mounting rails)

E-861 Controller/Driver for NEXACT® Systems

Networkable Controller for NEXACT® Ceramic Linear Drives and Positioners



- For NEXACT® Drives and Positioning Systems
- Complete System with Controller, Integrated Power Amplifiers and Software
- Open-Loop Operation, or Closed-Loop with Linear Encoder
- High Performance at Low Cost
- Daisy-Chain Networking for Multi-Axis Operation
- Non-Volatile Macro Storage for Stand-Alone Functionality with Autostart Macro
- I/O for Automation, Joystick for Manual Operation
- Parameter Changes On-the-Fly

PiezoWalk® System: E-861.1A1 NEXACT® Controller with open-loop N-310.01 NEXACT® linear drive; suitable for installation in stage with linear encoder

The new, compact E-861 controller is designed to operate NEXACT® linear drives and closed-loop positioning systems using them, simply and precisely. In perfect harmony with the mechanics, the E-861 supports both motion modes of the PiezoWalk® stepping drive: for longer moves, the stepping mode, and for moves shorter than typically 7 µm, the analog mode, which provides high-dynamics positioning with resolutions of less than 1 nm. The NEXACT® drive design minimizes piezo operating voltages to 45 V and below.

Flexible Automation

E-861 controllers offer a number of features to support automation and handling. For example, macros can be stored in non-volatile memory.

A programmable autostart macro allows stand-alone operation without external communication. Upon power-up, the macro with its internal command sequence is executed automatically.

For easy synchronization of motion with internal or external trigger signals, four input and four output lines are provided.

Multi-Axis Operation

Up to 16 E-861 controllers can be networked and controlled over a single PC interface.

Such daisy chain networks are flexible, can be extended at any time and are compatible with other PI controllers (e.g. DC servo-motor and stepper motor controllers).

Ordering Information

E-861.1A1
NEXACT® Controller, 1 Channel,
Linear Encoder

Easy System Setup, Comprehensive Software

All parameters can be set and checked by software. System setup and configuration is done with the included PIMikroMove® user-interface software. Interfacing to custom software is facilitated with included LabView drivers and DLLs. With the PI General Command Set (GCS), system programming is the same with all PI controllers, so controlling a system with a variety of different controllers is possible without difficulty.

Technical Data

	E-861.1A1
Function	Controller for NEXACT® drives / systems
Drive type	N-310.01 NEXACT® linear drive
Channels	1
Motion and control	
Servo characteristics	P-I-D-amplifier, parameter change on-the-fly
Trajectory profile modes	Trapezoidal
Encoder input	Analog encoder input sine-cosine interpolation circuit preset for differential transmission, 1 V _{pp} amplitude and 2.27 V offset of the encoder signal
Stall detection	Servo off, triggered by programmable position error
Input limit switch	2 x TTL (pull-up/pull-down, programmable)
Input reference switch	1 x TTL
Electrical properties	
Output power	max. 40 W
Output voltage	-10 to +45 V
Current consumption	max. 2 A
Interfaces and operation	
Communication interfaces	USB 1.0, RS-232 (9-pin (m) D-Sub)
Motor connector	D-Sub 15-pin (f) High Density
Sensor connector	D-Sub 15-pin (m) High Density
Controller network	Up to 16 units on single interface
I/O ports	4 analog/digital in, 4 digital out (TTL)
Command set	PI General Command Set (GCS)
User software	PIMikroMove®, PI Terminal
Software drivers	GCS-DLL, LabVIEW drivers
Supported functionality	Start-up macro; data recorder for categories like current position or velocity; internal safety circuitry: watchdog timer
Manual control (optional)	Joystick, Y-cable for 2D motion, pushbutton box
Miscellaneous	
Operating voltage	24 V included: external power supply, 24 V, 2.5 A
Operating temperature range	0 to +50 °C
Mass	1.1 kg
Dimensions	206 x 130 x 66 mm (with mounting rails)



The E-755 Controller for NEXLINE® high-force linear motor actuators (models N-111, N-214, N-215, etc.)

For more information visit www.pi.ws

E-625 Controller for Piezo (Flexure) Actuators

Compact Piezo Amplifier & Servo-Controller with High-Speed Interface



E-625.SR (left) and E-625.CR compact piezo servo-controllers.

- Controls Piezo Flexure Actuators/Stages and Stack Actuators
- Network Capability with up to 4 Channels
- For Capacitive, LVDT and Strain Gauge Position Sensors
- Wave Table for User-Defined Curves
- Integrated 20-Bit High-Speed RS-232 Interface

The E-625 is a bench-top piezo linear amplifier and position servo controller with integrated high-speed RS-232 computer interface and 20-bit D/A converters. The low-noise amplifier can supply/sink a peak current of 140 mA in a voltage range of -20 to 120 V. Versions are available to operate with SGS, LVDT or capacitive position sensors, making the servo-controller suitable for a wide variety of PI piezo actuators and nanopositioning stages.

New and Fast Communications Interface

The RS-232 interface handles the communications with the outside world. It performs up to 300 highly deterministic read or write operations per second and incorporates precision 20-bit D/A and A/D converters for exceptional positional stability and resolution.

Multi-Axis Network

Up to four E-625s with any combination of capacitive, SGS

and LVDT sensors can be networked and controlled over a single RS-232 connection. Between the individual E-625s, parallel networking with optional E-625.CN cables is used providing higher data rates than possible with serial links.

Wave Table

User-defined data-points, calculated with any arbitrary function, can be stored in a wave table in the E-625 for later output under control of an external trigger.

Software / GCS Command Set

The E-625 controller comes with Windows™ installation software, DLLs and Lab View™ drivers. The command structure of the extensive command set is based on the PI General Command Set (GCS). The GCS was developed by PI to facilitate the programming and operation of a wide range of different devices with a common command language, thus reducing the programming

effort in the face of complex multi-axis positioning tasks. It is also supported by the E-516 Computer Interface Module, and most PI nanopositioning controllers and motor controllers. For more information on GCS, see p. 9-28.

Ordering Information

- E-625.SR**
LVPZT Piezo Amplifier & Servo-Controller, Strain Gauge Sensor, RS-232 Interface
- E-625.LR**
LVPZT Piezo Amplifier & Servo-Controller, LVDT Sensor, RS-232 Interface
- E-625.CR**
LVPZT Piezo Amplifier & Servo-Controller, Capacitive Sensor, RS-232
- E-625.CN**
Network Cable for Connecting two E-625s

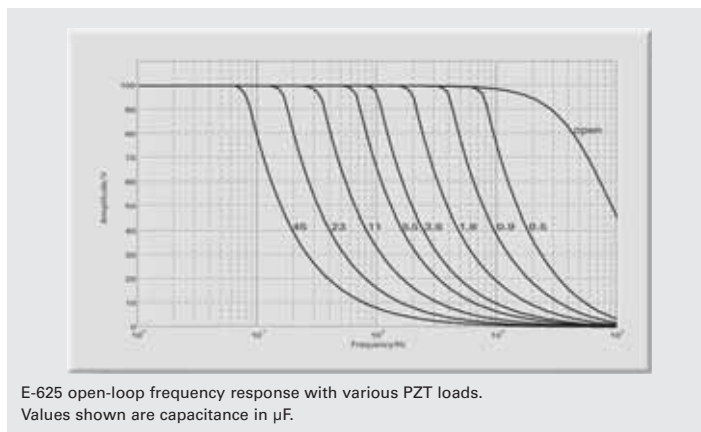

E-625 open-loop frequency response with various PZT loads. Values shown are capacitance in μF .

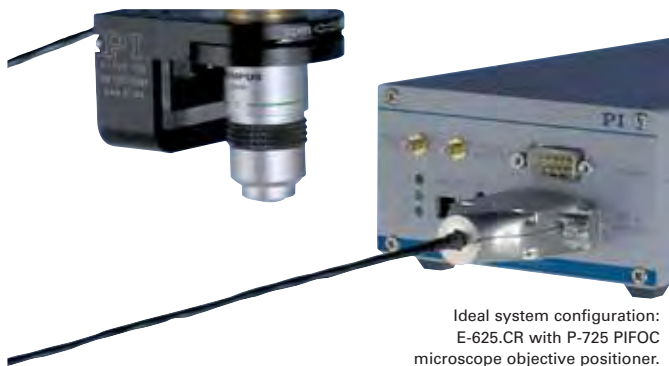

Ideal system configuration: E-625.CR with P-725 PIFOC microscope objective positioner.

Visit www.pi.ws for for our full selection of Piezo Controllers

Piezo · Nano · Positioning

PI



Two single-channel piezo controllers: E-625 and the more powerful E-665 (background).

Technical Data

Models	E-625.SR, E-625.LR, E-625.CR
Function	Power amplifier & position servo-control of LVPZTs
Channels	1
Amplifier	
Output voltage	-20 to +120 V
Maximum output power	11 W (s. p. 6-52)
Average output power	6 W
Peak output current <5 ms	140 mA
Average output current	60 mA
Current limitation	Short-circuit proof
Voltage gain	10 ±0.1
Polarity	Positive
Input Impedance	100 kΩ
Dimensions	205 x 105 x 60 mm
Mass	1050 g
Operating voltage	12 to 30 VDC, stabilized
Operating current	2 A
Interface	
D/A converter	20-bit resolution
A/D converter (sensor)	20-bit resolution
Networking	4 channels, parallel
RS-232 baudrate	9.6 kBaud–115.2 kBaud (default 115.2)
Wave table	64 values, 100 Hz, externally triggered
Position Servo-Control	
Sensor types	Capacitive (E-625.CR), Strain gauge (E-625.SR), LVDT (E-625.LR)
Servo characteristics	P-I analog, notch filter
Connectors	
PZT connector	LEMO ERA.00.250.CTL / Sub-D Mix (.CR)
Sensor connector	LEMO EPL.0S.304.HLN (.SR, .LR) / Sub-D Mix (.CR)
Analog input	SMB
Monitor output	SMB
RS-232	9-pin sub-D (male)

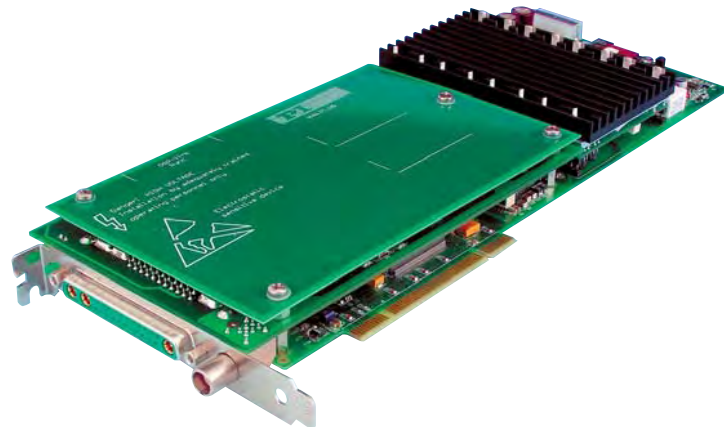

E-761 Digital Piezo Controller in PCI-Board Format. For more information visit www.pi.ws



The hardbound "Piezo Nano Positioning Inspirations 2009" catalog from PI is available now. The 530 page publication is the most comprehensive reference book on the fundamentals of nanopositioning, piezo systems and micropositioning technology yet. The catalog contains 200 products with more than 1000 drawings, graphs, images and technical diagrams.

The 530 page publication presents PI's state-of-the-art products and technologies – such as:

- Nanopositioning / Scanning Stages
- Scanning Microscopy Stages
- Steering Mirrors, Mirror Shifters
- Piezo Actuators
- Piezo Motors
- Piezo Controllers
- Motorized Stages & Actuators
- Motor Controllers
- Hexapod 6-Axis Alignment Systems

The catalog also contains a tutorial on piezo technology and application examples of nanopositioning products in the following industries:

- Biotechnology / Life Sciences
- Semiconductor Technology
- Data Storage
- Nanotechnology
- Aeronautics
- Astronomy
- Adaptive Optics
- Metrology / Laser-Systems
- Precision Machining

Headquarters

GERMANY

Physik Instrumente (PI) GmbH & Co. KG
 Auf der Römerstr. 1
 76228 Karlsruhe/Palmbach
 Tel: +49 (721) 4846-0
 Fax: +49 (721) 4846-100
 info@pi.ws · www.pi.ws

PI Ceramic GmbH
 Lindenstr.
 07589 Lederhose
 Tel: +49 (36604) 882-0
 Fax: +49 (36604) 882-25
 info@piceramic.de
 www.piceramic.de

Subsidiaries

USA (East) & CANADA

PI (Physik Instrumente) L.P.
 16 Albert St.
 Auburn, MA 01501
 Tel: +1 (508) 832 3456
 Fax: +1 (508) 832 0506
 info@pi-usa.us
 www.pi-usa.us

USA (West) & MEXICO

PI (Physik Instrumente) L.P.
 5420 Trabuco Rd., Suite 100
 Irvine, CA 92620
 Tel: +1 (949) 679 9191
 Fax: +1 (949) 679 9292
 info@pi-usa.us
 www.pi-usa.us

JAPAN

PI Japan Co., Ltd.
 Akebono-cho 2-38-5
 Tachikawa-shi
 Tokyo 190
 Tel: +81 (42) 526 7300
 Fax: +81 (42) 526 7301
 info@pi-japan.jp
 www.pi-japan.jp

PI Japan Co., Ltd.
 Hanahara Dai-ni-Building, #703
 4-11-27 Nishinakajima,
 Yodogawa-ku, Osaka-shi
 Osaka 532
 Tel: +81 (6) 6304 5605
 Fax: +81 (6) 6304 5606
 info@pi-japan.jp
 www.pi-japan.jp

CHINA

Physik Instrumente (PI Shanghai) Co., Ltd.
 Building No. 7-301
 Longdong Avenue 3000
 201203 Shanghai, China
 Tel: +86 (21) 687 900 08
 Fax: +86 (21) 687 900 98
 info@pi-china.cn
 www.pi-china.cn

UK & IRELAND

PI (Physik Instrumente) Ltd.
 Trent House
 University Way,
 Cranfield Technology Park,
 Cranfield,
 Bedford MK43 0AN
 Tel: +44 (1234) 756 360
 Fax: +44 (1234) 756 369
 uk@pi.ws
 www.physikinstrumente.co.uk

FRANCE

PI France S.A.S.
 32 rue Delizy
 93694 Pantin Cedex
 Tel: +33 (1) 57 14 07 10
 Fax: +33 (1) 41 71 18 98
 info@pifrance.fr
 www.pifrance.fr

ITALY

Physik Instrumente (PI) S.r.l.
 Via G. Marconi, 28
 20091 Bresso (MI)
 Tel: +39 (02) 665 011 01
 Fax: +39 (02) 610 396 56
 info@pionline.it
 www.pionline.it